



# Rigging and Installation Manual

LPT SERIES FORCED DRAFT COOLING TOWERS.  
LRW SERIES FORCED DRAFT CLOSED CIRCUIT COOLERS  
LRC FORCED DRAFT EVAPORATIVE CONDENSERS

EVAPCO Products are Manufactured Worldwide

EVAPCO, Inc. — World Headquarters & Research/Development Center

EVAPCO, Inc. • P.O. Box 1300 • Westminster, MD 21158 USA  
PHONE: 410-756-2600 • FAX: 410-756-6450 • E-MAIL: [marketing@evapco.com](mailto:marketing@evapco.com)

## EVAPCO North America

### EVAPCO, Inc.

**World Headquarters**  
P.O. Box 1300  
Westminster, MD 21158 USA  
Phone: 410-756-2600  
Fax: 410-756-6450  
E-mail: [marketing@evapco.com](mailto:marketing@evapco.com)

**EVAPCO East**  
5151 Allendale Lane  
Taneytown, MD 21787 USA  
Phone: 410-756-2600  
Fax: 410-756-6450  
E-mail: [marketing@evapco.com](mailto:marketing@evapco.com)

**EVAPCO Midwest**  
1723 York Road  
Greenup, IL 62428 USA  
Phone: 217-923-3431  
Fax: 217-923-3300  
E-mail: [evapcomw@evapcomw.com](mailto:evapcomw@evapcomw.com)

**EVAPCO West**  
1900 West Almond Avenue  
Madera, CA 93637 USA  
Phone: 559-673-2207  
Fax: 559-673-2378  
E-mail: [contact@evapcowest.com](mailto:contact@evapcowest.com)

**EVAPCO Iowa**  
925 Quality Drive  
Lake View, IA 51450 USA  
Phone: 712-657-3223  
Fax: 712-657-3226

**EVAPCO Iowa Sales & Engineering**  
215 1st Street, NE  
P.O. Box 88  
Medford, MN 55049 USA  
Phone: 507-446-8005  
Fax: 507-446-8239  
E-mail: [evapcomn@evapcomn.com](mailto:evapcomn@evapcomn.com)

**EVAPCO Northwest**  
P.O. Box 1727  
Lake Oswego, Oregon 97035 USA  
Phone: 503-639-2137  
Fax: 503-639-1800

**EVAPCO Newton**  
701 East Jourdan Street  
Newton, IL 62448 USA  
Phone: 618-783-3433  
Fax: 618-783-3499  
E-mail: [evapcomw@evapcomw.com](mailto:evapcomw@evapcomw.com)

**EVAPCO-BLCT Dry Cooling, Inc.**  
981 US Highway 22 West Bridgewater,  
New Jersey 08807 USA Phone: 1-  
908-379-2665  
E-mail: [info@evapco-blct.com](mailto:info@evapco-blct.com)

**Refrigeration Valves & Systems Corporation**  
*A wholly owned subsidiary of EVAPCO, Inc.*  
1520 Crosswind Dr.  
Bryan, TX 77808 USA  
Phone: 979-778-0095  
Fax: 979-778-0030  
E-mail: [rvs@rvscorp.com](mailto:rvs@rvscorp.com)

**EvapTech, Inc.**  
*A wholly owned subsidiary of EVAPCO, Inc.*  
8331 Nieman Road  
Lenexa, KS 66214 USA  
Phone: 913-322-5165  
Fax: 913-322-5166  
E-mail: [marketing@evaptech.com](mailto:marketing@evaptech.com)

**Tower Components, Inc.**  
*A wholly owned subsidiary of EVAPCO, Inc.*  
5960 US HWY 64E  
Ramseur, NC 27316  
Phone: 336-824-2102  
Fax: 336-824-2190  
E-mail: [mail@towercomponentsinc.com](mailto:mail@towercomponentsinc.com)

## EVAPCO Europe

**EVAPCO Europe BVBA European Headquarters**  
Industrieterrein Oost 4010  
3700 Tongeren, Belgium  
Phone: (32) 12-395029  
Fax: (32) 12-238527  
E-mail: [evapco.europe@evapco.be](mailto:evapco.europe@evapco.be)

**EVAPCO Europe, S.r.l.**  
Via Ciro Menotti 10  
I-20017 Passirana di Rho  
Milan, Italy  
Phone: (39) 02-939-9041  
Fax: (39) 02-935-00840  
E-mail: [evapcoeuropa@evapco.it](mailto:evapcoeuropa@evapco.it)

**EVAPCO Europe, S.r.l.**  
Via Dosso 2  
23020 Piateda Sondrio, Italy

**EVAPCO Europe, GmbH**  
Meerbuscher Straße 64-78  
Haus 5  
40670 Meerbusch, Germany  
Phone: (49) 2159-69560  
Fax: (49) 2159-695611  
E-mail: [info@evapco.de](mailto:info@evapco.de)

**Flex coil a/s**  
*A wholly owned subsidiary of EVAPCO, Inc.*  
Knošgårdvej 115  
DK-9440 Aabybro Denmark  
Phone: (45) 9824 4999  
Fax: (45) 9824 4990  
E-mail: [info@flexcoil.dk](mailto:info@flexcoil.dk)

**EVAPCO S.A. (Pty.) Ltd.**  
*A licensed manufacturer of EVAPCO, Inc.*  
18 Quality Road  
Isando 1600  
Republic of South Africa  
Phone: (27) 11-392-6630  
Fax: (27) 11-392-6615  
E-mail: [evapco@evapco.co.za](mailto:evapco@evapco.co.za)

**Evap Egypt Engineering Industries Co.**  
*A licensed manufacturer of EVAPCO, Inc.*  
5 El Nasr Road  
Nasr City, Cairo, Egypt  
Phone: 2 02 24022866/2 02 24044997  
Fax: 2 02 24044667/2 02 24044668  
E-mail: [Primacool@link.net](mailto:Primacool@link.net) / [Shady@primacool.net](mailto:Shady@primacool.net)

## EVAPCO Asia/Pacific

**EVAPCO Asia/Pacific Headquarters**  
1159 Luoning Rd. Baoshan Industrial Zone  
Shanghai, P. R. China, Postal Code: 200949  
Phone: (86) 21-6687-7786  
Fax: (86) 21-6687-7008  
E-mail: [marketing@evapcochina.com](mailto:marketing@evapcochina.com)

**EVAPCO (Shanghai) Refrigeration Equipment Co., Ltd.**  
1159 Louning Rd., Baoshan Industrial Zone  
Shanghai, P.R. China, Postal Code: 200949  
Phone: (86) 21-6687-7786  
Fax: (86) 21-6687-7008  
E-mail: [marketing@evapcochina.com](mailto:marketing@evapcochina.com)

**Beijing EVAPCO Refrigeration Equipment Co., Ltd.**  
Yan Qi Industrial Development District  
Huai Rou County  
Beijing, P.R. China, Postal Code: 101407  
Phone: (86) 10 6166-7238  
Fax: (86) 10 6166-7395  
E-mail: [evapcobj@evapcochina.com](mailto:evapcobj@evapcochina.com)

**EVAPCO Australia (Pty.) Ltd.**  
34-42 Melbourne Road  
P.O. Box 436  
Riverstone, N.S.W. Australia 2765  
Phone: (61) 2 9627-3322  
Fax: (61) 2 9627-1715  
E-mail: [sales@evapco.com.au](mailto:sales@evapco.com.au)

**EVAPCO Composites Sdn. Bhd**  
No. 70 (Lot 1289) Jalan Industri 2/3  
Rawang Integrated Industrial Park  
Rawang, Selangor, 48000 Malaysia  
Phone: 60 3 6092-2209  
Fax: 60 3 6092-2210

**EvapTech Asia Pacific Sdn. Bhd**  
*A wholly owned subsidiary of EvapTech, Inc.*  
IOI Business Park, 2/F Unit 20  
Persiaran Puchong Jaya Selatan  
Bandar Puchong Jaya,  
47170 Puchong, Selangor, Malaysia  
Phone: (60-3) 8070-7255  
Fax: (60-3) 8070-5731  
E-mail: [marketing-ap@evaptech.com](mailto:marketing-ap@evaptech.com)

Visit EVAPCO's Website at: <http://www.evapco.com>

**EVAPCO...SPECIALISTS IN HEAT TRANSFER PRODUCTS AND SERVICES.**



### Method of Shipment

---

Forced draft units are shipped fully assembled. Miscellaneous items, such as sealer, self-tapping screws and any other required materials, are packaged and placed inside the pan for shipment.

**NOTE:** All hoods and attenuation packages are factory inspected prior to shipment to verify proper fit for rigging. Please take extra care to handle and rig unit section per the instructions of this manual to avoid possible distortion and poor casing alignment. It is advisable to check each section upon receipt and during each lift to ensure that the factory alignment has not been altered. Should the field inspection indicate the section alignment ("square") has been altered, please contact the factory or your local EVAPCO representative for additional instructions to obtain proper section fit.

### Storage

---

Do not place tarps or other coverings over the top of the units if the units are to be stored before installation. Excessive heat can build up if the units are covered causing possible damage to the PVC eliminators. For extended storage beyond six months rotate the fan and fan motor shaft(s) monthly. Also, the fan shaft bearings should be purged and regreased prior to start-up.

### General

---

For extended lifts, or where hazards may exist, it is recommended that safety slings and spreaders be employed for safety. Refer to the extended lift information in this bulletin.

### International Building Code Provisions

---

The International Building Code (IBC) is a comprehensive set of regulations addressing the structural design and installation requirements for building systems— including HVAC and industrial refrigeration equipment. As of June 2008, all 50 states plus Washington D.C. have adopted the International Building Code. The code provisions require that evaporative cooling equipment and all other components permanently installed on a structure must meet the same seismic design criteria as the building. The LPT Series Cooling Towers, LR Series Coolers and Condensers are IBC 2009 compliant up to 1g with standard construction and up to 5.12g with additional structural modifications.

All items attached to the EVAPCO LPT Cooling Tower, Evapco LR Closed Circuit Cooler or LR Evaporative Condenser must be independently reviewed and isolated to meet applicable wind and seismic loads. This includes piping, ductwork, conduit, and electrical connections. These items must be flexibly attached to the Evapco unit so as not to transmit additional loads to the equipment as a result of seismic or wind forces.

### Structural Steel Support

---

Two structural "I" beams running the length of the unit are required for supporting the unit. These beams should be located underneath the outer flanges of the unit as shown in Figure 1. See Table 1 for Steel Support Dimensions. Table 1 lists units according to the nominal plan area of their heat transfer section. Overall dimensions will be different.

Mounting holes, 19mm in diameter, are located in the bottom flange for bolting to the structural steel. Refer to the recommended structural steel support drawing and certified print for exact bolt hole location. Bolt the bottom section to the steel support before rigging any hoods or attenuation.

Beams should be sized in accordance with accepted structural practices. Maximum deflection of the beam under the unit should be 1/360 of the unit length, not to exceed 13mm. Deflection may be calculated by using 55% of the operating weight as a uniform load on each beam (see certified print for operating weight).

The supporting "I" beams should be level to within 1.5mm in 1m before setting the unit. Do not level the unit by shimming between the bottom flange and the beams as this will not provide proper longitudinal support.

**NOTE:** Consult IBC 2009 for required steel support layout and structural design.

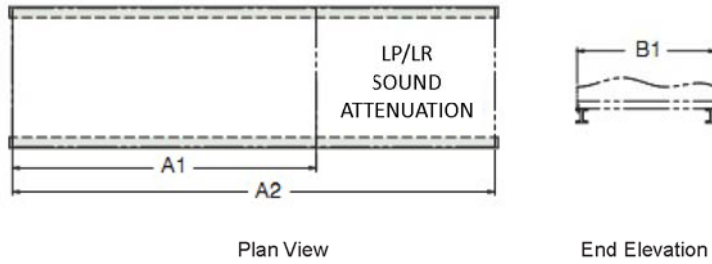

Figure 1 – Structural Steel Support

Model	A1(Unit only) (mm)	A2(Unit with Intake Attn.) (mm)	B1 (mm)
LPT 316~366, LRC 25~72, LRW 18-2E~18~5H	3096	4027	1029
LPT 516~596, LRC 76~114, LRW 30-2G~30-5H	3731	4842	1540
LPT 519~569, LRC 108~183, LRW 45-3I~45-6J	4630	5741	1540
LPT 5112-5712, LRC 190~246, LRW 60-3K~60-6M	5554	6665	1540
LPT 819-879, LRC 188~269, LRW 72-3K~72-5L	4630	5741	2388
LPT 8112~8812, LRC 249~379, LRW 96-4L~96-6N	5554	6665	2388

Table 1 – Steel Support Dimensions

## Rigging the Main Unit

Lifting devices are located on the sides of the unit near the bottom as shown in Figure 2a. It is recommended that units be lifted using a boom oriented along the length of the unit with the cables straddling the unit at the lift points (Figure 2a). An alternative method is to lift the unit with a single hook, lashing the cables to the lift points on the unit directly (Figure 2b). Spreader bars are necessary in both cases to prevent damage to the sides of the unit.

When a boom is used, the distance "A" between the lift points on the boom should be set equal to the distance between the lift points on the unit and the crane hook must be located a minimum distance "H1" above the top of the unit as shown in Figure 2a. When no boom is used, the crane hook must be a minimum distance "H2" above the lifting points on the unit as shown in Figure 2b.

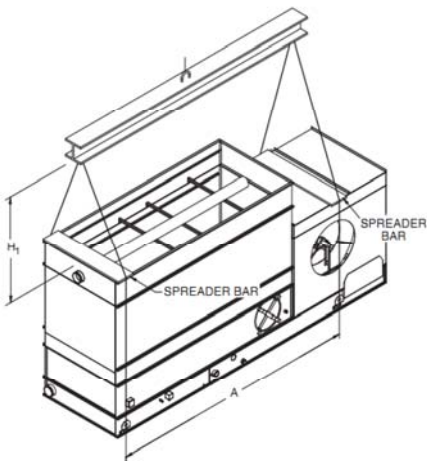

Figure 2a – Recommended Rigging - LP/LR Main Unit

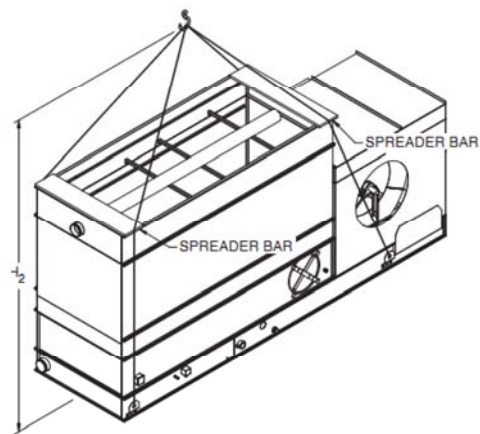

Figure 2b – Alternate Rigging - LP/LR Main Unit





Table 2 shows minimum “H” dimensions and gives “A” dimensions for the different unit sizes.

**Table 2** —Dimensional Guidelines for Lift Cables.  
Dimensions Refer to Drawings in Figure 2a and 2b.

Model	A Towers (mm)	A cooler/ Condensers (mm)	H1 (m)	H2 (m)
LPT 316~366 LRC 25~72 LRW 18-2E~18-5H	2185	2185	0.9	3
LPT 516~596 LRC 76~114 LRW 30-2G~30-5H	2591	2591	1.5	3.6
LPT 519~569 LRC 108~183 LRW 45-3I~45-6J	3480	3480	1.5	4
LPT 5112-5712 LRC 190~246 LRW 60-3K~60-6M	4420	4420	1.5	4.3
LPT 819-879 LRC 188~269 LRW 72-3K~72-5L	3506	3379	2.1	5.2
LPT 8112~8812 LRC 249~379 LRW 96-4L~96-6N	4420	4293	2.1	6

## Extended Lifts

The recommended method for extended lifts is to use slings under the unit (Figures 3a and 3b). Safety slings, spreaders and skids should be removed before final positioning of the unit.

**NOTE:** Always use safety slings for extended lifts or where any safety hazard exists.

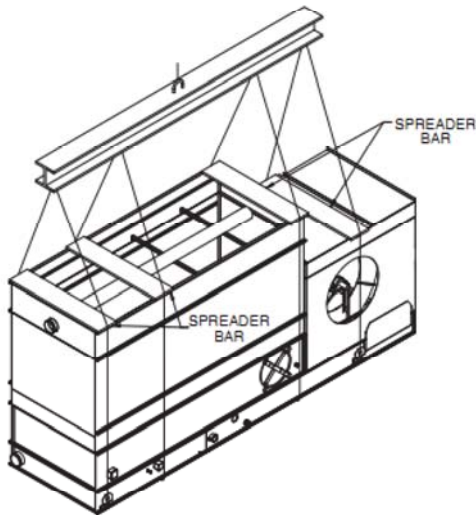

Figure 3a – Recommended Safety Sling Rigging

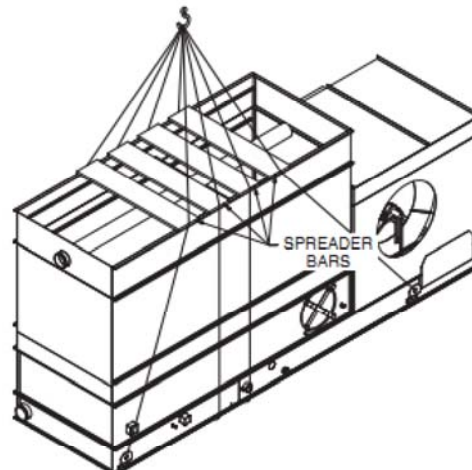
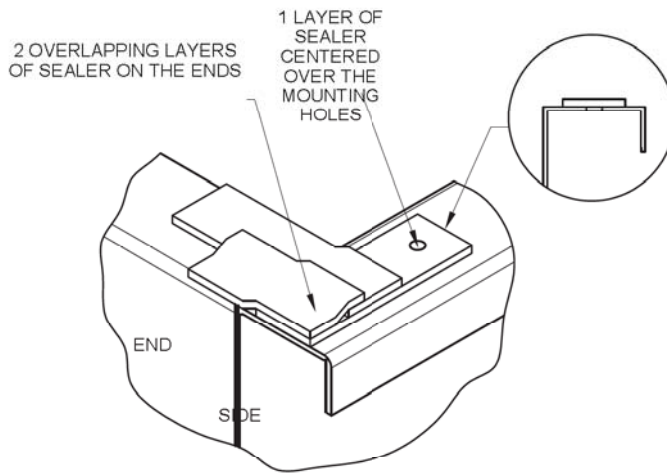

Figure 3b – Alternative Safety Sling Rigging

## Applying Sealer Tape

If the unit was shipped with optional discharge attenuation or discharge hoods sealer tape must be applied prior installation of the section. Once the unit has been set on the supporting steel and bolted in place, wipe the top flanges to remove any dirt or moisture. Place sealer tape over the mounting hole centerline on the side flanges. Apply two strips of sealer tape, one partially overlapping the other, on the end flanges.

The sealer tape should overlap on the corners as shown in Figure 4. Do not splice the sealer tape along the end flanges and preferably not on the side flanges if it can be avoided. Always remove the paper backing from the sealer tape.



**Figure 4 – Proper Sealer Tape Application**  
Hood or attenuation only

## Rigging and Assembling Discharge and Intake Accessories

Intake sound attenuators and discharge hoods/discharge attenuators are not assembled to the main unit when shipped and must be separately rigged and assembled in the field. Four accessories fall into this group - discharge hood (may be straight or tapered), discharge attenuation, fan-end sound attenuator and fan side attenuators. These are shown mounted in Figure 5 and construction details are referenced to Figures 6, 8 and 10 respectively.

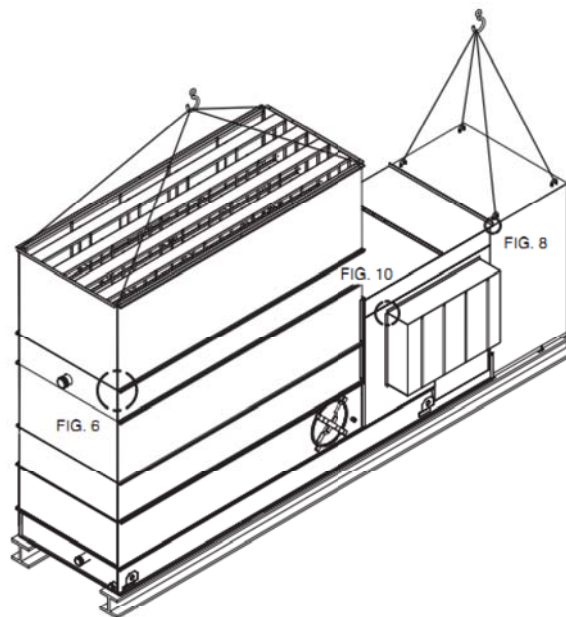
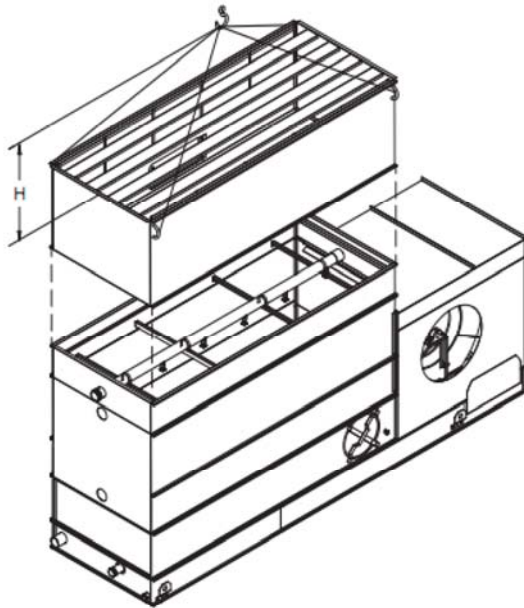

**Figure 5 – Discharge and Intake Accessory Rigging**



**Rigging Discharge Hoods and Discharge Attenuators**

Discharge Hoods may be either straight or tapered. Discharge Attenuators will be straight-sided. Both must be rigged with a separate lift after the main unit has been secured to the structural supports. The rigging for both types of accessories is shown in Figures 6a and 6b. The lifting cables must be long enough to allow the crane hook to be a minimum dimension "H" above the top of the assembly. These "H" values are given in Table 3.



**Figure 6a** – Rigging Straight Discharge Hood or Discharge Attenuation

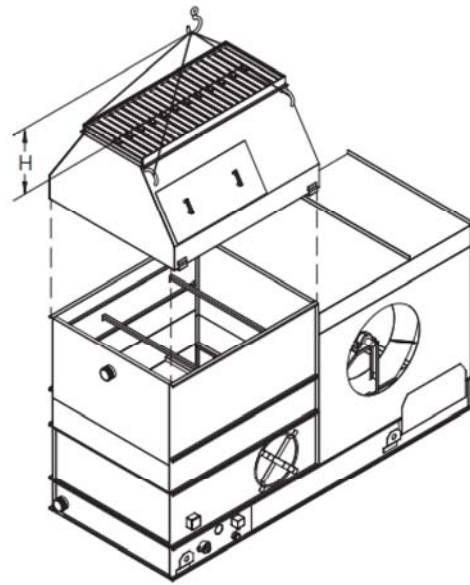
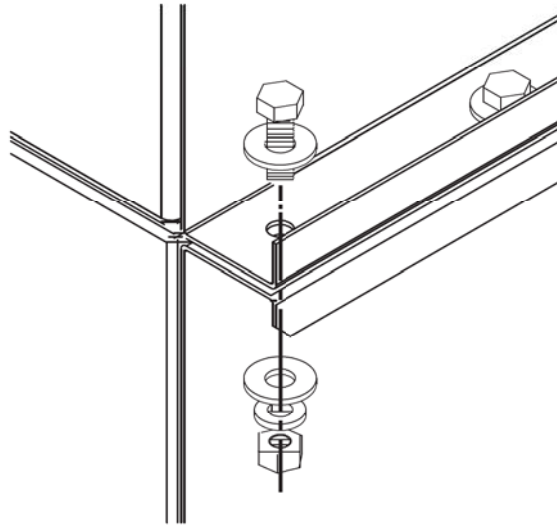

**Figure 6b** – Rigging Tapered Discharge Hood

**Table 3** – "H" Dimensions for Discharge Hoods

Model	H (m)
LPT 316~366 LRC 25~72 LRW 18-2E~18-5H	2.4
LPT 516~596 LRC 76~114 LRW 30-2G~30-5H	2.4
LPT 519~569 LRC 108~183 LRW 45-3I~45-6J	3
LPT 5112-5712 LRC 190~246 LRW 60-3K~60-6M	4.5
LPT 819-879 LRC 188~269 LRW 72-3K~72-5L	3
LPT 8112~8812 LRC 249~379 LRW 96-4L~96-6N	4.5

Galvanized and stainless steel units use M8 nuts and bolts to secure the hood or attenuation to the casing. Construction details referenced in Figure 4 are shown in Figure 7 below.



**Figure 7** – Discharge Hood or Attenuation Assembly Details

### Rigging Fan End Sound Attenuation

Fan end sound attenuators must be rigged with a separate lift after the main unit has been secured to the structural supports. The rigging for the fan-end sound attenuator assembly is shown in Figure 8. The lifting cables must be long enough to allow the crane hook to be a minimum dimension "H" above the top of the assembly. These "H" values are given in Table 4.

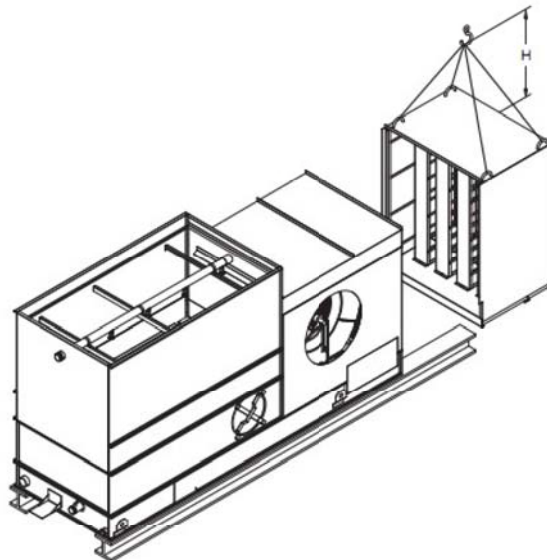

**Figure 8** – Rigging Fan-End Sound Attenuator Assembly



**Table 4 – “H” Dimensions for Fan-End Sound Attenuator Assembly**

Model	H (m)
LPT 316~366 LRC 25~72 LRW 18-2E~18-5H	1.2
LPT 516~596 LRC 76~114 LRW 30-2G~30-5H	1.5
LPT 519~569 LRC 108~183 LRW 45-3I~45-6J	1.5
LPT 5112-5712 LRC 190~246 LRW 60-3K~60-6M	1.5
LPT 819-879 LRC 188~269 LRW 72-3K~72-5L	2.4
LPT 8112~8812 LRC 249~379 LRW 96-4L~96-6N	2.4

On galvanized units, the fan-end sound attenuator housing is secured on the sides and top with 8mm self-tapping bolts. On stainless steel units, the fan-end sound attenuator housing is secured on the sides using 6mm threaded machine bolts that are set into rivnuts located in the side panel of the main unit and on the top using 8mm stainless steel nuts and bolts. Construction details referenced in Figure 5 are shown in Figure 9. At the time the fan-side attenuator is fitted to the main unit, be sure that the fan belt adjustment extension tube at the base of the fan-end sound attenuator assembly is properly mated with the hex head fitting at the main unit.

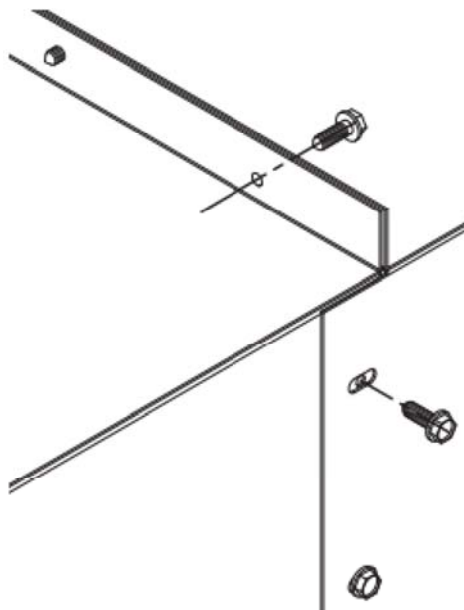

**Figure 9 – Fan-End Sound Attenuator Assembly Details**



## Rigging Fan-Side Attenuators

On galvanized units, the fan-side sound attenuators are secured to the main unit using 8mm self-tapping bolts. On stainless steel units, it is secured using 6mm threaded machine bolts which are set into rivnuts located in the side panel of the unit. Assembly is shown in Figure 10 and construction details referenced in Figure 5 are shown in Figure 11 below.

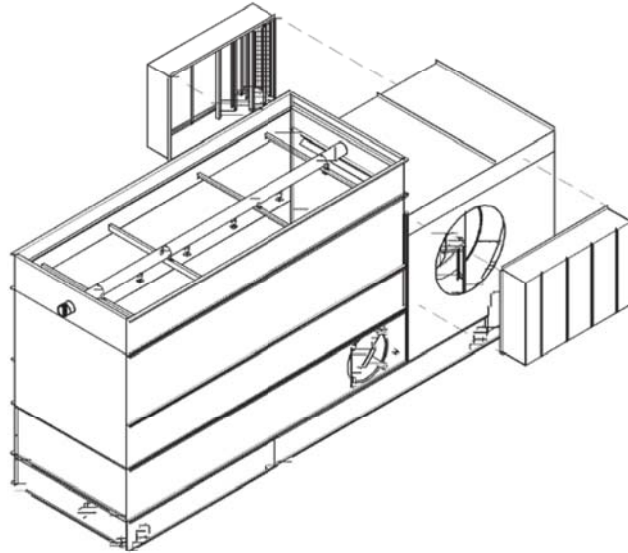

Figure 10 – Rigging Fan-Side Sound Attenuator Assembly

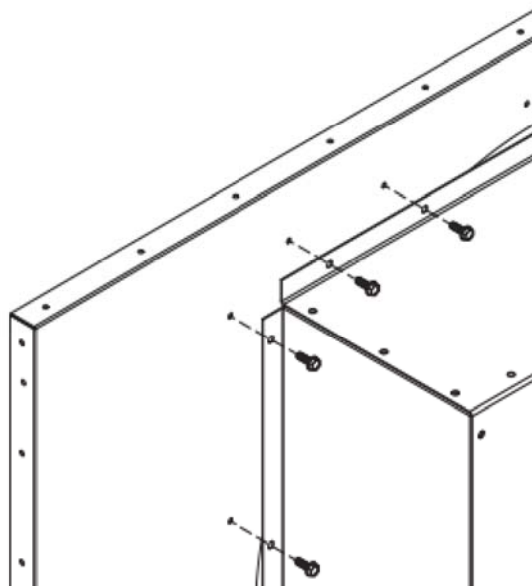

Figure 11 – Fan-Side Sound Attenuator Assembly Details



## Final Assembly and Start-up Details

**Shipping Materials** - Remove any wood chocks, spare parts, or miscellaneous items that have been placed inside the unit for shipping purposes. Clean all debris from the basin.

**Pump Discharge Line** - Connect the riser pipe from the pump discharge on the pan-fan section to the riser pipe on the coil section using the flexible connection and hose clamps provided.

**Bleed-off Line** - A bleed-off line and valve are installed on the unit when shipped with a pump. On units shipped without a pump (remote sump applications) make sure a bleed-off line and valve are properly sized and installed on the discharge side of the pump and connected to a convenient drain. In either case, the bleed-off valve should be fully open.

**Strainer** - Check the strainer in the basin to ensure that it is in its proper location over the pump suction as shown in Figures 12a and 12b.

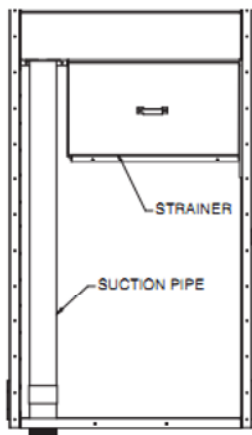

Figure 12a – Strainer Location on 1m and 1.5m Wide Units.

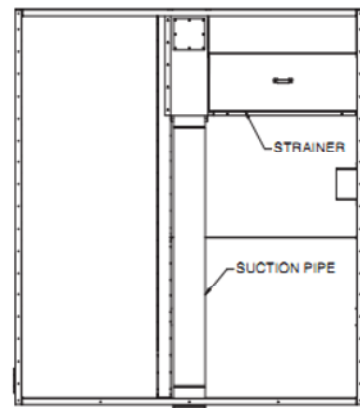

Figure 12b – Strainer Location on 2.5m Wide Units.

**Screens** - Protective air inlet screens are provided across the front of the fan section of all models. Screens are not provided on the bottom of the fan section since most of the units are mounted on steel beams, either on the roof or at ground level. If units are installed in an elevated position, bottom screens are recommended for safety protection and should be provided by the installing contractor.

**Float Valve Adjustment** - The float valve is pre-set at the factory, however adjustment should be checked after rigging. The float valve should be adjusted so that the center of the float is 25.4mm below the center of the overflow connections when the valve is in the fully closed position. Raise or lower the float by using the wing nuts on the vertical threaded rod. Do not adjust the horizontal rod. During normal operation, the water level will drop 76.2mm to 101.6mm below the overflow in condensers and coolers; and to approximately 127mm to 152.4mm below the overflow in cooling towers. See Table 5 for normal operating level for the LR and LP style units.

Table 5 – Minimum Operating Level

Model	Minimum Level (mm)
LPT 316~366, LRC 25~72, LRW 18-2E~18-5H	204
LPT 516~596, LRC 76~114, LRW 30-2G~30-5H	204
LPT 519~569, LRC 108~183, LRW 45-3I~45-6J	204
LPT 5112-5712, LRC 190~246, LRW 60-3K~60-6M	204
LPT 819-879, LRC 188~269, LRW 72-3K~72-5L	204
LPT 8112~8812, LRC 249~379, LRW 96-4L~96-6N	204



**Fan Rotation** - Bump start and check the fans for proper rotation. Directional arrows are placed on the outside of centrifugal fan housings or on the inside of axial fan cylinders.

**Pump Rotation** - Bump start and check the pump for proper rotation. Directional arrows are found on the pump impeller housing.

### Freeze Protection

The simplest and most effective way of keeping the recirculated water from freezing is to use a remote sump. With a remote sump, when the recirculating water pump is shut off all recirculating water drains back to the sump.

If a remote sump is not being used, pan heaters are available. However, the basin heater will not prevent the external water lines, pump or pump piping from freezing. For installations where water will be left in the basin during freezing conditions, the make-up water supply, overflow and drain lines, as well as the pump and pump piping up to the overflow level must be heat traced and insulated to protect them from damage. Any other connections or accessories at or below the water level must also be heat traced and insulated.

**The pan heaters are designed to prevent pan water from freezing when the unit is idle (no fan). If the unit will be operated dry (no water over coil) but will not be completely drained, please consult EVAPCO marketing to upsize the heaters.**

### Maintenance

Once the installation is complete and the unit is turned on, it is important that it be properly maintained. Maintenance is not difficult or time-consuming but must be done regularly to assure full performance of the unit. Refer to the operation and maintenance instructions supplied with the unit for proper maintenance procedures.

### Water Treatment

Proper water treatment is an essential part of the maintenance required for evaporative cooling equipment. Galvanized equipment should be passivated prior to equipment startup to avoid the formation of white rust. For more information on passivation and white rust, please download a copy of EVAPCO's Engineering Bulletin 36 at [www.evapco.com](http://www.evapco.com). The spray water and the fluid inside the heat transfer coil should both be maintained with a water treatment program to ensure efficient system operation while maximizing the equipments service life. For more information on recommended water chemistry for EVAPCO equipment, see the Operation and Maintenance Instructions for this equipment.

### Rigging Hardware Parts List

Table 6 lists those parts which are shipped together with the unit(s) for field assembly and/or spare parts. These parts will be found in a cardboard box wrapped in plastic and secured in the basin of the unit.

**Table 6 – LP Tower and LR Cooler and Condenser Attenuation and Discharge Hood Rigging Box Parts List**  
(galvanized and stainless steel construction)

Model	Extra Nozzles	Bolt 5/16" x 1"	Hex Nut 5/16"	Flat Washer 5/16"	Lock Washer 5/16"	Sealer Tape
LPT 316~366, LRC 25~72, LRW 18-2E~18-5H	1	14	14	28	14	2
LPT 516~596, LRC 76~114, LRW 30-2G~30-5H	1	14	14	28	14	2
LPT 519~569, LRC 108~183, LRW 45-3I~45-6J	1	22	22	44	22	3
LPT 5112-5712, LRC 190~246, LRW 60-3K~60-6M	1	24	24	48	24	3
LPT 819-879, LRC 188~269, LRW 72-3K~72-5L	2	22	22	44	22	3
LPT 8112~8812, LRC 249~379, LRW 96-4L~96-6N	2	24	24	48	24	3



## Accessory Location Checklist

Accessories can ship in a variety of locations depending on the type of accessory, the size of the unit and the accessories purchased with the unit. See Table 7 for a guide to accessory location.

Table 7 – Unit Accessory Shipping Location

Unit Accessories	Shipping Location
Aluminum Ladder	Shipped Separately on Truck Bed
Discharge Attenuation	Shipping Location is Unit Dependent - If Space is Available: Loosely Mounted on Unit - If No Space is Available: Shipped Separately on Truck Bed
Discharge Hood with Dampers	Shipping Location is Unit Dependent - If Space is Available: Loosely Mounted on Unit - If No Space is Available: Shipped Separately on Truck Bed
Electric Basin Heater	Shipping Location is Unit Dependent - End Mounted Heater: Installed in Unit Basin - Side Mounted Heater: Strapped Inside Unit Basin
Electric Basin Heater Control Panel	Shipping Location is Dependent on Control Panel Size and Unit Width - If Space is Available: Mounted on Unit Basin - If No Space is Available: Boxed, Wrapped and Wire Tied Inside Unit Basin
Electric Basin Heater Low Water Cutout	Shipped in Rigging Box Strapped Inside Unit Basin
Electric Basin Heater Thermostat	Shipping Location is Unit Dependent - End Mounted Thermostat: Mounted on Unit Basin - Side Mounted Thermostat: Shipped in Rigging Box
Electronic Water Level Control Probes	Mounted in PVC standpipe
Electronic Water Level Control	PVC Standpipe Strapped Inside Unit Basin
Factory Mounted Crossover Piping	Welded to Coil Connections
Fan Screens (If not mounted)	Shipping Location is Unit and Accessory Dependent - If Space is Available: Strapped Inside Unit Basin - If No Space is Available: Crated and Shipped Separately on Truck Bed
Hot Water or Steam Coil	Installed in Unit Basin
Inlet Attenuation	Shipping Location is Unit Dependent - If Space is Available: Loosely Mounted on Unit - If No Space is Available: Shipped Separately on Truck Bed
Remote Sump Trash Screen	Installed In Unit Basin
Rigging Hardware	Shipped in Rigging Box Strapped Inside Unit Basin
Safety Cage	Attached to the Ladder
Sealer Tape	Shipped in Rigging Box Strapped Inside Unit Basin
Sump Sweeper Piping with and without High Flow Eductors	Installed in Unit Basin
Vibration Switch	Mounted in Fan Section
Water Silencers	Installed in Unit Basin



EVAPCO Asia/Pacific Headquarters, 1159 Luoning Rd.  
Baoshan Industrial Zone, Shanghai, P.R.China

PHONE: (86)21-66877786 • FAX: (86)21-66877008 • E-MAIL: [marketing@evapcochina.com](mailto:marketing@evapcochina.com)