

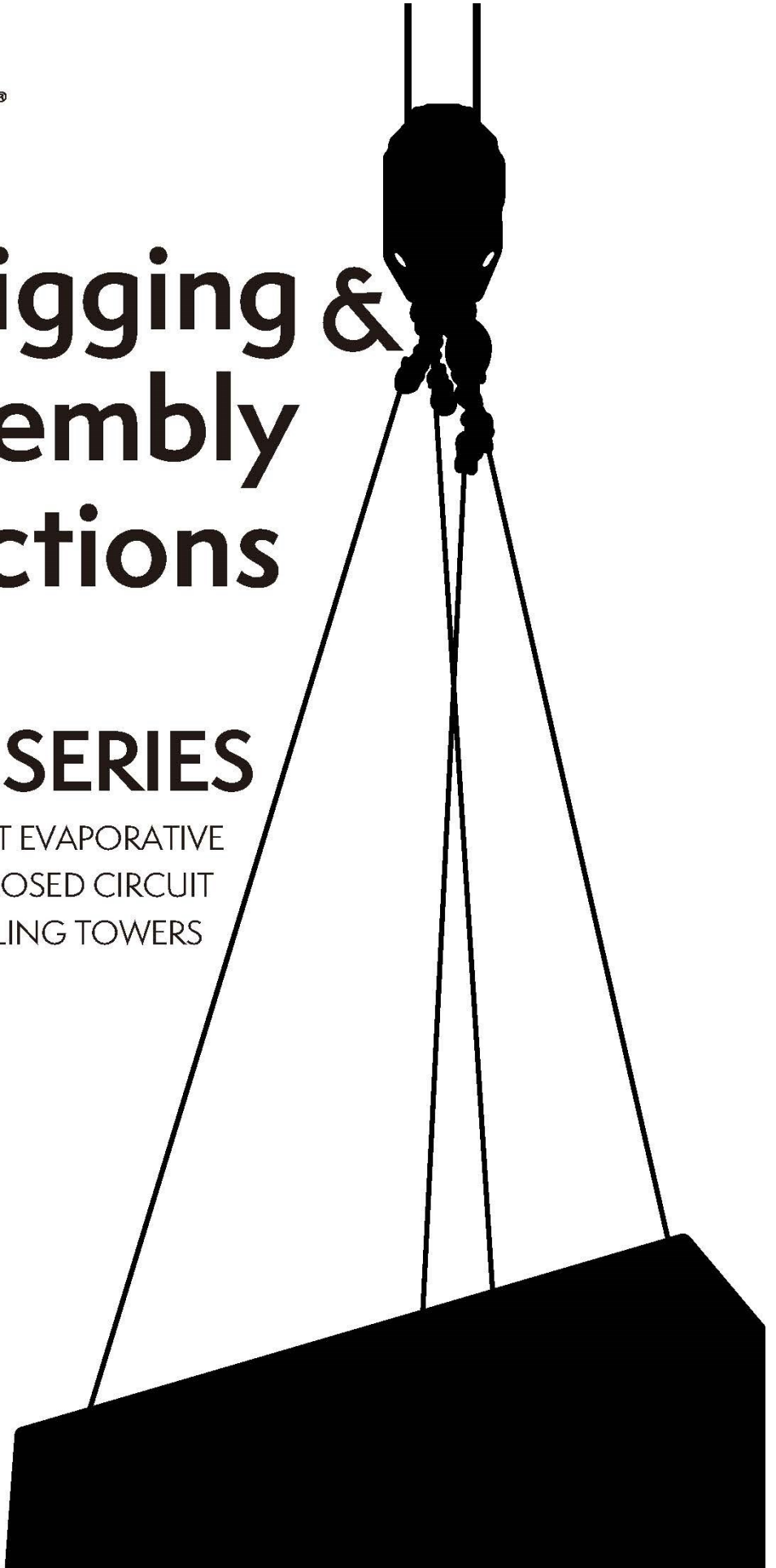

Rigging & Assembly Instructions

LS SERIES

FORCED DRAFT EVAPORATIVE
CONDENSERS, CLOSED CIRCUIT
COOLERS, & COOLING TOWERS



Mr. GoodTower®



Bulletin LS2ORIG



Table of Contents

EVAPCO Contact Information	2
Method of Shipment	4
Storage	4
General	4
International Building Code Provisions	4
Structural Steel Support	4-5
Rigging Pan/Fan Section	6-7
Applying Sealer Tape	8
Rigging the Coil or Fill Section	8-11
Assembly of the Coil or Fill Section to the Pan/Fan Section	11
Rigging Complete Units	12-13
Optional Tapered or Straight-Sided Hood Section	14
Optional Discharge Attenuation Section	15
Optional Intake Attenuation Section	16
Motor Installation (1.2m and 1.6m Wide Models)	17
Final Assembly and Start-Up Details	18
Freeze Protection	19
Water Treatment	19
Maintenance	19
Accessory Location Checklist	20
Notes	21

The LS SERIES OF FORCED DRAFT EVAPORATIVE CONDENSERS, CLOSED CIRCUIT COOLERS, AND COOLING TOWERS should be rigged and assembled using the instructions and recommendations outlined in this bulletin.

All personnel should review these procedures, as well as the latest industry-approved installation practices, prior to rigging and assembly. The information in this bulletin is for informational purposes only. These instructions do not purport to cover all variations and possible contingencies in connection with installation. Additionally, the procedures described therein are subject to change without prior notice, due to EVAPCO, Inc.' s ongoing research and development.

EVAPCO, Inc. makes no representations or warranties with respect to these instructions or the products described herein. Nor shall EVAPCO, Inc. be responsible for any loss or damage (direct, indirect, consequential, or other) during installation or handling of equipment after shipment.

For a full description of EVAPCO' s liability policy, please visit www.evapcoasia.com to access our Terms and Conditions.

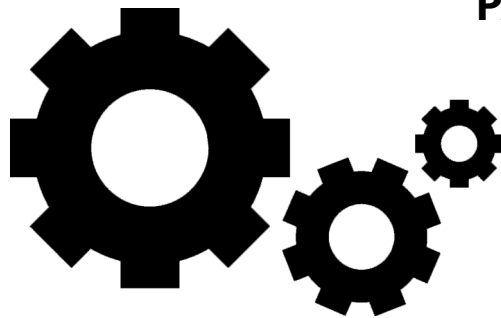

**FOR EVPCO AUTHORIZED
PARTS AND SERVICE,
CONTACT YOUR
LOCAL EVAPCO
REPRESENTATIVE
OR THE LOCAL
SERVICE CENTER**



EVAPCO Asia/Pacific

1159 Luoning Rd, Baoshan Industrial Zone, Shanghai, China 200949

PHONE: (86) 21-6687-7786 · FAX: (86) 21-6687-7008 · E-MAIL: marketing@evapcochina.com

EVAPCO North America

EVAPCO, Inc.
World Headquarters
P.O. Box 1300
Westminster, MD 21158 USA
410-756-2600 p | 410-756-6450 f
marketing@evapco.com

EVAPCO East
5151 Allendale Lane
Taneytown, MD 21787 USA
410-756-2600 p | 410-756-6450 f
marketing@evapco.com

EVAPCO East
Key Building
Taneytown, MD USA
410-756-2600 p
marketing@evapco.com

EVAPCO Midwest
Greenup, IL USA
217-923-3431 p
evapcomw@evapcomw.com

EVAPCO West
Madera, CA USA
559-673-2207 p
contact@evapcowest.com

EVAPCO Iowa
Lake View, IA USA
712-657-3223 p

EVAPCO Iowa
Sales & Engineering
Medford, MN USA
507-446-8005 p
evapcomn@evapcomn.com

EVAPCO Newton
Newton, IL USA
618-783-3433 p
evapcomw@evapcomw.com

EVAPCO IL
Greenup, IL USA
217-923-3431 p
evapcomw@evapcomw.com

EVAPCO-BLCT Dry Cooling, Inc.
1011 US Highway 22 West
Bridgewater, NJ 08807 USA
Phone: 1-908-379-2665
E-mail: info@evapco-blct.com

EVAPCO-BLCT Dry Cooling, Inc.
7991 Shaffer Parkway
Littleton, CO 80127 USA
Phone: 1-908-379-2665
E-mail: info@evapco-blct.com
Spare Parts Phone: 908-895-3236
Spare Parts e-mail: spares@evapco-blct.com

EVAPCO Power México S. de R.L. de C.V.
Calle Iglesia No. 2, Torre E
Tizapan San Angel, Del. Álvaro Obregón
Ciudad de México, D.F. México 01090
Phone: +52 (55) 8421-9260
e-mail: info@evapco-blct.com

Refrigeration Valves & Systems Corporation
A wholly owned subsidiary of EVAPCO, Inc.
Bryan, TX USA
979-778-0095 p
rvs@rvscoip.com

EvapTech, Inc.
A wholly owned subsidiary of EVAPCO, Inc.
Lenexa, KS USA
913-322-5165 p
marketing@evaptech.com

Tower Components, Inc.
A wholly owned subsidiary of EVAPCO, Inc.
Rambleur, NC USA
336-824-2102 p
mail@towercomponentsinc.com

EVAPCO Alcol, Inc.
A wholly owned subsidiary of EVAPCO, Inc.
York, PA USA
717-347-7500 p
Info@alcol.net

EVAPCO Europe

EVAPCO Europe BVBA
European Headquarters
Heersterveldweg 19
Industrieterrein Oost
3700 Tongeren, Belgium
(32) 12-395029 p | (32) 12-238527 f
evapco.europe@evapco.be

EVAPCO Europe, S.r.l.
Milan, Italy
(39) 02-939-9041 p
evapcoeuropa@evapco.it

EVAPCO Europe, S.r.l.
Sondrio, Italy

EVAPCO Europe GmbH
Meerbusch, Germany
(49) 2159-6956 18 p
info@evapco.de

EVAPCO Air Solutions
A wholly owned subsidiary of EVAPCO, Inc.
Aabybro, Denmark
(45) 9824 4999 p
info@evapco.dk

EVAPCO Air Solutions GmbH
Garbsen, Germany
(49) 5137 93875-0 p
Info@evapcoas.de

Evap Egypt Engineering Industries Co.
A licensed manufacturer of EVAPCO, Inc.
Nasr City, Cairo, Egypt
2 02 24022866 / 2 02 24044997 p
primacool@link.net / shedy@primacool.net

EVAPCO S.A. (Pty.) Ltd.
A licensed manufacturer of EVAPCO, Inc.
Isando 1600, Republic of South Africa
(27) 11-392-6630 p
evapco@evapco.co.za

EVAPCO Asia/Pacific

EVAPCO Asia/Pacific Headquarters
1159 Luoning Road
Baoshan Industrial Zone
Shanghai 200949, P.R. China
(86) 21-6687-7786 p | (86) 21-6687-7008 f
marketing@evapcochina.com

EVAPCO (Shanghai) Refrigeration Equipment Co., Ltd.
1159 Luoning Road, Shanghai, P.R. China
(86) 21-6687-7786 p
marketing@evapcochina.com

EVAPCO (Beijing) Refrigeration Equipment Co., Ltd.
No.66 the 4th Block, Yanqi Economic Development Zone, Huairou District, Beijing 101407, P.R.China
(86) 10-6166-7238 p
marketing@evapcochina.com

EVAPCO Australia (Pty.) Ltd.
Riverstone NSW 2765, Australia
(61) 2 9627-3322 p
sales@evapco.com.au

EVAPCO Composites Sdn. Bhd
Rawang, Selangor, Malaysia
(60-3) 8092-2209 p

EvapTech Asia Pacific Sdn. Bhd
A wholly owned subsidiary of EvapTech, Inc.
Puchong, Selangor, Malaysia
(60-3) 8070-7255 p
marketing-ap@evaptech.com

EVAPCO South America

EVAPCO Brasil
Equipamentos Industriais Ltda.
Al. Vênus, 151 – CEP: 13347-659
Indaiatuba – São Paulo – Brasil
(55+11) 5681 2000 p
[vendas@evapco.com.br](mailto: vendas@evapco.com.br)

Fan Technology Resource
Cruz das Almas – Indaiatuba
São Paulo, Brasil 13308-200
55 (11) 4025-1670
fantr@fantr.com

EVAPCO...SPECIALISTS IN HEAT TRANSFER PRODUCTS AND SERVICES.

Visit EVAPCO' s Website at: <http://www.evapcoasia.com>



Method of Shipment

Forced draft units are shipped either fully assembled (for smaller units) or with the top section(s) separate from the bottom section(s). These sections have mating flanges and will join together in a waterproof joint when sealed and bolted together as described in the following instructions.

Miscellaneous items, such as sealer, fasteners, and any other required materials, are packaged and placed inside the pan for shipment.

NOTE: All casing sections are factory inspected prior to shipment to verify proper fit for rigging. Please take extra care to handle and rig unit sections per the instructions of this manual to avoid possible distortion and poor casing alignment. It is advisable to check each section upon receipt and during each lift to ensure that the factory alignment has not been altered. Should the field inspection indicate the section alignment ("square") has been altered, please contact the factory or your local EVAPCO sales representative for additional instructions to obtain proper section fit.

Storage

Do not place tarps or other coverings over the top of the units if the units are to be stored before installation. Excessive heat can build up if the units are covered causing possible damage to the PVC eliminators. For extended storage beyond six months, rotate the fan and fan motor shaft(s) monthly. Also, the fan shaft bearings should be purged and regreased prior to start-up.

General

For extended lifts, or where hazards may exist, it is recommended that safety slings and spreaders be employed for safety. Refer to the extended lift information in this bulletin for more details.

International Building Code Provisions

The International Building Code (IBC) is a comprehensive set of regulations addressing the structural design and installation requirements for building systems—including HVAC and industrial refrigeration equipment. All 50 states plus Washington, D.C. have adopted the International Building Code. The code provisions require that evaporative cooling equipment and all other components permanently installed on a structure must meet the same seismic design criteria as the building. The LS Series of condensers, coolers, and cooling towers are IBC compliant.

All items attached to the EVAPCO LS Evaporative Condenser, LS Closed Circuit Cooler, or LS Cooling Tower must be independently reviewed and isolated to meet applicable wind and seismic loads. This includes piping, ductwork, conduit, and electrical connections. These items must be flexibly attached to the EVAPCO unit so as not to transmit additional loads to the equipment as a result of seismic or wind forces.

Structural Steel Support

Two structural I-beams running the length of the unit are required for supporting the unit. These beams should be located underneath the outer flanges of the unit as shown in **Figure 1**. See **Table 1** for Steel Support Dimensions.

Mounting holes, 19mm in diameter, are located in the bottom flange for bolting to the structural steel. Refer to the recommended structural steel support drawing and certified print for exact bolt hole location. Bolt the bottom section to the steel support before rigging the top section.

Beams should be sized in accordance with accepted structural practices. Maximum deflection of the beam under the unit should be 1/360 of the unit length, not to exceed 13mm. Deflection may be calculated by using 55% of the operating weight as a uniform load on each beam (see certified print for operating weight).

Do not level the unit by shimming between the bottom flange and the beams as this will not provide proper longitudinal support.

NOTE: Consult the latest version of the IBC code for required steel support layout and structural design.

Table 1 – Steel Support Dimensions

Unit (Width x Length) (m)	B1 (Unit Only) (mm)	B2 (Compact Attenuation Option) (mm)	B3 (Basic Attenuation Option) (mm)	B4 (Extended Attenuation Option) (mm)	A (mm)
1.2 x 1.8	1235	2378	2648	3048	1826
1.2 x 2.7	1235	2378	2648	3048	2724
1.2 x 3.6	1235	2378	2648	3048	3645
1.2 x 5.4	1235	2378	2648	3048	5486
1.6 x 3.6	1651	2794	3064	3453	3645
1.6 x 5.4	1651	2794	3064	3453	5484
2.4 x 3.6	2388	3531	3801	4188	3651
2.4 x 5.4	2388	3531	3801	4188	5486
2.4 x 7.3	2388	3531	3801	4188	7341
2.4 x 11 COIL	2388	3531	3801	4188	11011
2.4 x 11 TOWER	2388	3531	3801	4188	11030
3 x 3.6	2991	4134	4404	4791	3651
3 x 5.4	2991	4134	4404	4791	5493
3 x 7.3	2991	4134	4404	4791	7344
3 x 11 COIL	2991	4134	4404	4791	11027
3 x 11 TOWER	2991	4134	4404	4791	11036

Figure 1 – Structural Steel Support

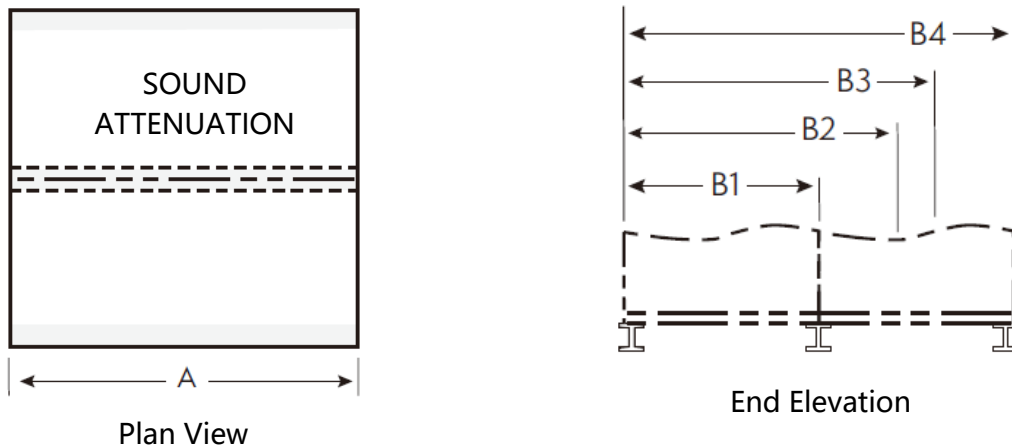

Rigging Pan/Fan Section

U-bolts or similar lifting points are located in the pan/fan section for lifting and final positioning purposes, as shown below in **Figures 2, 3, and 4**. Units with lengths up to 5.4m have 4 total lift points. Unit with length of 7.3m and 2.4m x 11m units have 6 total lift points. Other 3m x 11m units have 8 lift points.

NOTE: Use all of the U-bolts or lift points provided for lifting.

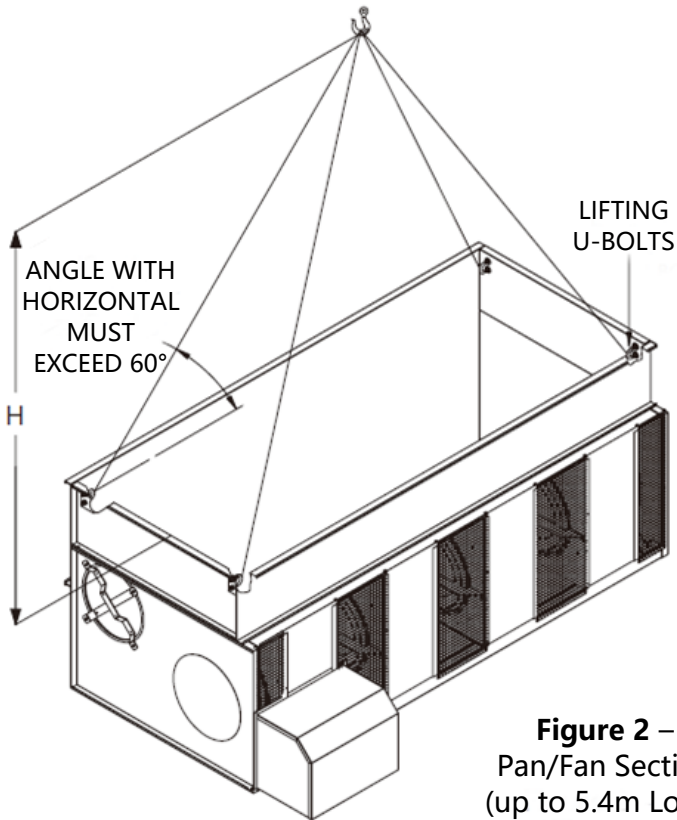

Figure 2 –
Pan/Fan Section
(up to 5.4m Long)

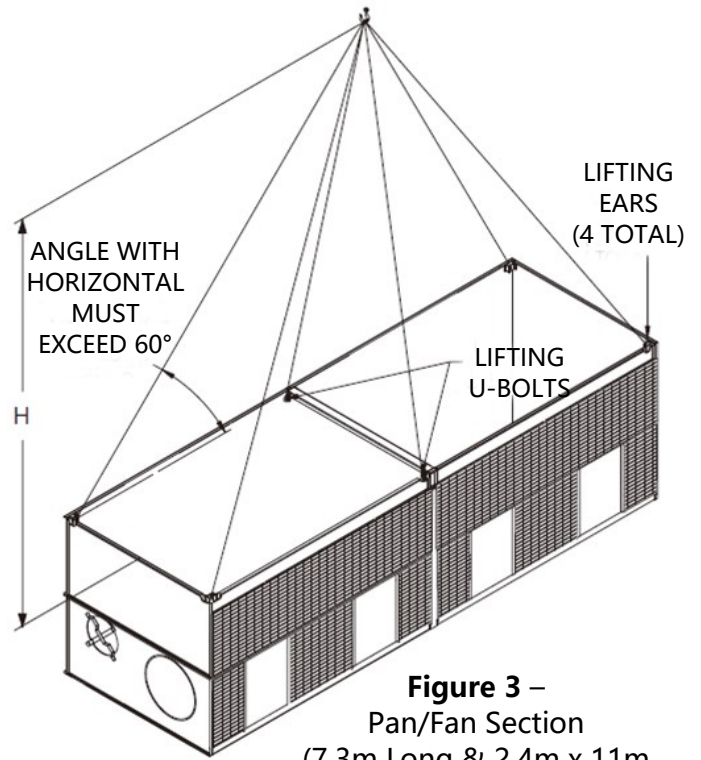

Figure 3 –
Pan/Fan Section
(7.3m Long & 2.4m x 11m
- 6 lift points shown)

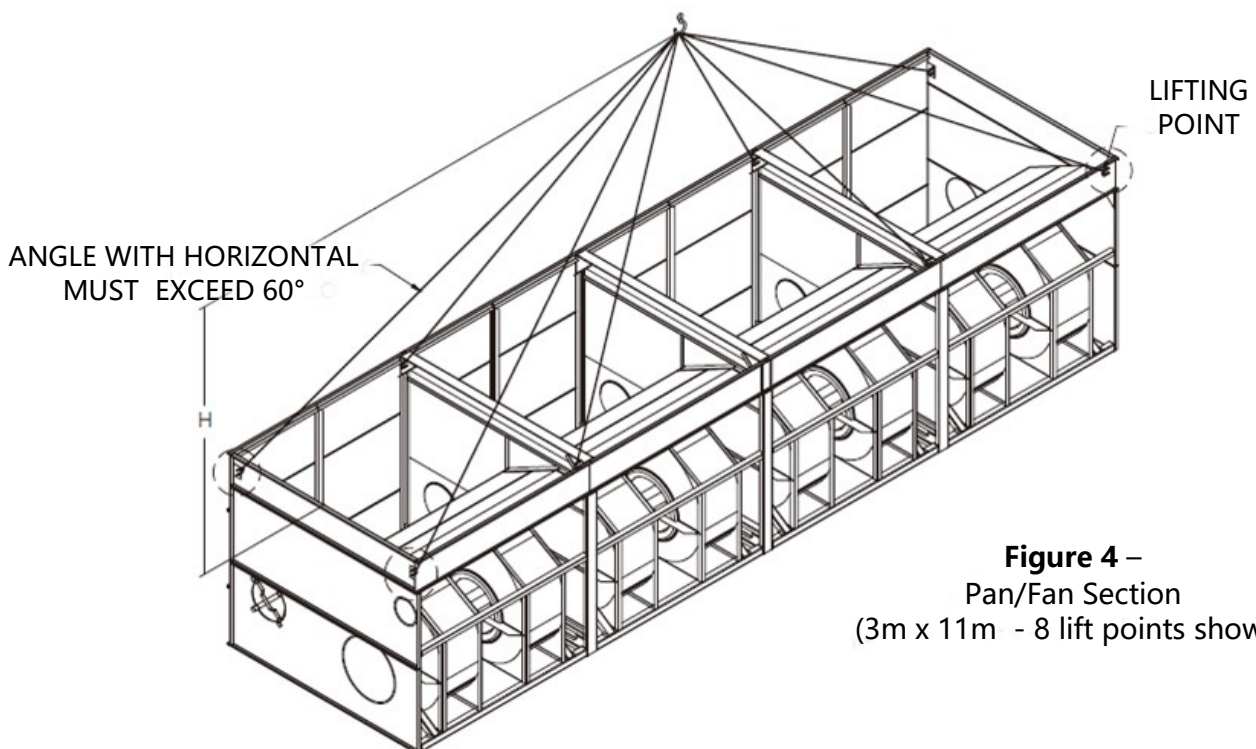

Figure 4 –
Pan/Fan Section
(3m x 11m - 8 lift points shown)

The recommended method for extended lifts is to use slings under the unit as shown in **Figures 5** and **6**. Spreader bars should always be used between the cables at the top of the section to prevent damage to the upper flanges.

NOTE: The U-bolts or other lifting points should be used for final positioning only and for lifting where no danger exists. If they are used for extended lifts, safety slings and spreader bars should be provided under the sections as shown.

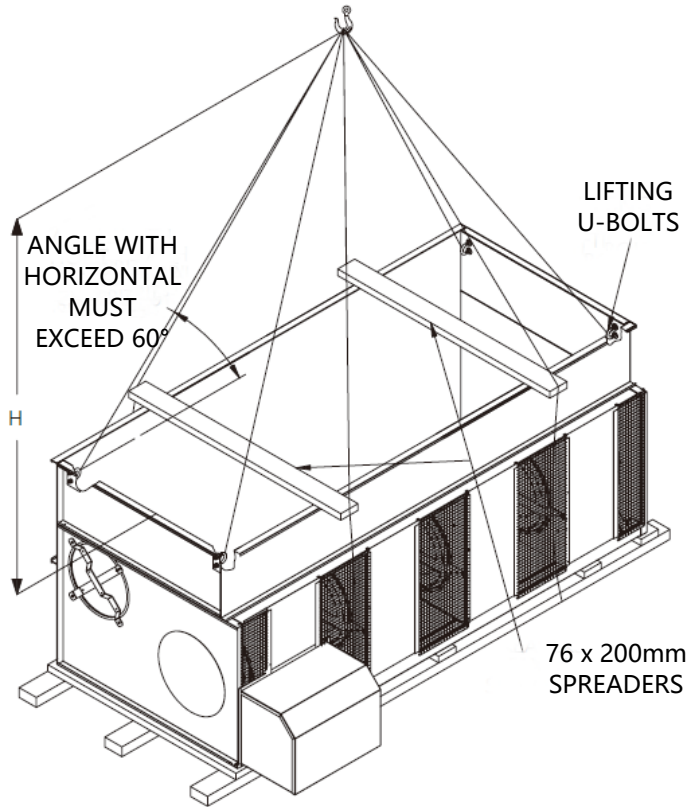

Figure 5 –
Extended Lift Pan/Fan Section
(up to 5.4m Long)

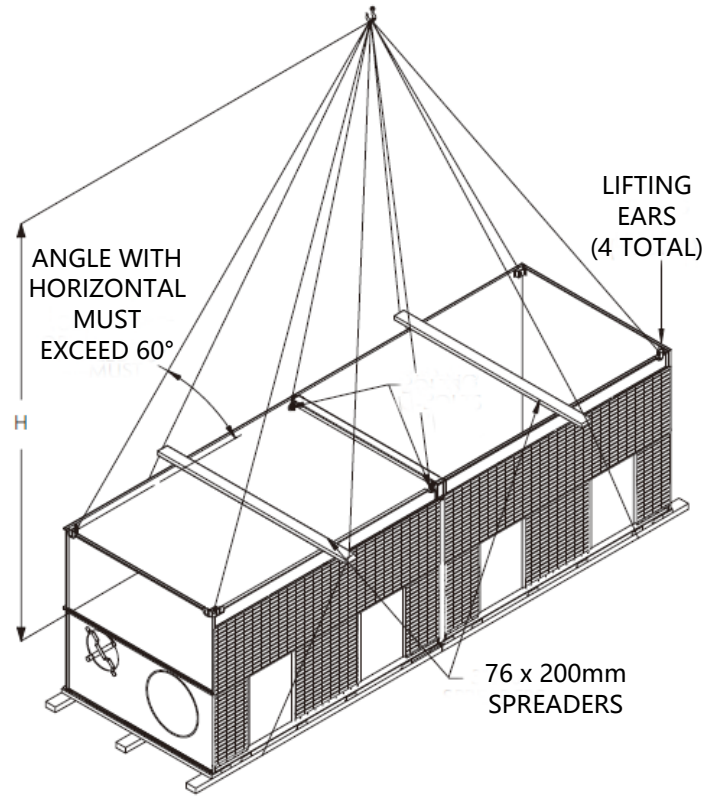

Figure 6 –
Extended Lift Pan/Fan Section
(7.3m & 11m Long - 6 lift points shown)

See **Table 2** for the minimum “H” dimensions for rigging the pan-fan assembly for both standard and extended lifts.

Table 2 – Minimum “H” Dimension for Pan/Fan Rigging

Unit (Width x Length) (m)	Minimum “H” (m)
1.2 x 1.8	2.5
1.2 x 2.7	3.1
1.2 x 3.6	4.6
1.2 x 5.4	5.8
1.6 x 3.6	4.6
1.6 x 5.4	5.8
2.4 x 3.6	4.6

Unit (Width x Length) (m)	Minimum “H” (m)
2.4 x 5.4	5.8
2.4 x 7.3	7.7
2.4 x 11	11.6
3 x 3.6	4.6
3 x 5.4	5.8
3 x 7.3	7.7
3 x 11	11.6

Applying Sealer Tape

Once the bottom section has been set on the supporting steel and bolted in place, wipe the top flanges to remove any dirt or moisture. Place sealer tape over the mounting hole centerline on the side flanges. Apply two strips of sealer tape, one partially overlapping the other, on the end flanges.

The sealer tape should overlap on the corners as shown in **Figure 7**. Do not splice the sealer tape along the end flanges and preferably not on the side flanges if it can be avoided. **Always remove the paper backing from the sealer tape.**

For units which have two or more casing sections, sealer tape must be applied to all internal flanges (**Figure 8**).

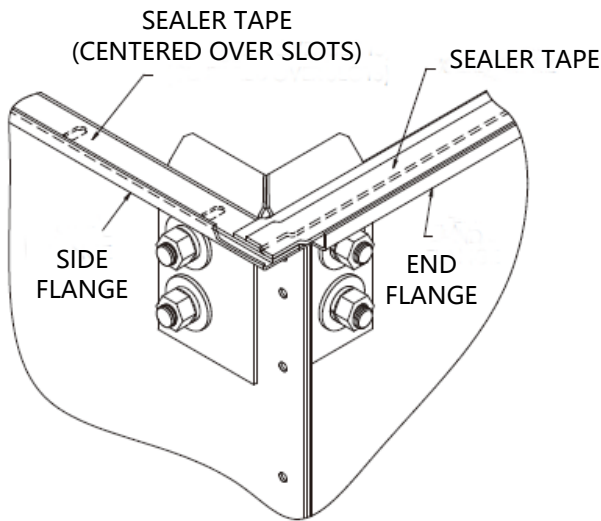

Figure 7 – Proper Sealer Tape Application

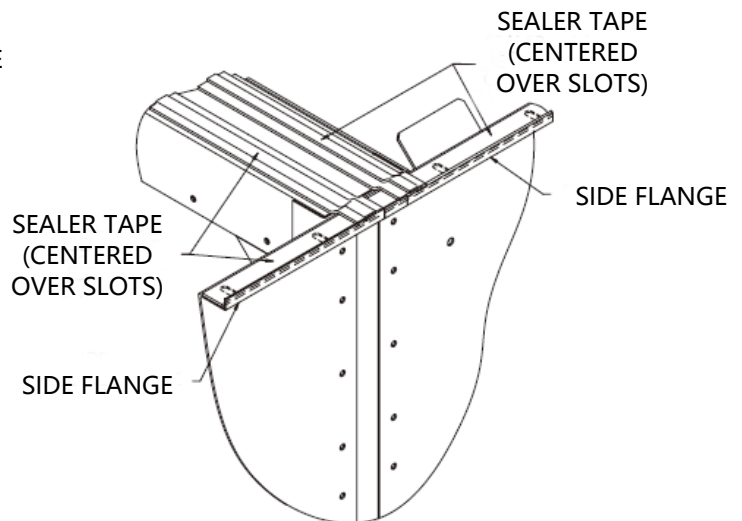

Figure 8 – Sealer Detail for Center Joint of Units with Two or More Casing Sections

Rigging the Coil or Fill Section

U-bolts or lift points are provided in the four corners of the coil section for lifting and final positioning (**Figure 9**). On larger coil sections which have 2 coils, there are additional lift points on the center (**Figure 10**). Refer to the certified drawing for the coil section weight.

U-bolts or lift points are provided in the four corners of the fill section for lifting and final positioning (**Figure 11**). Refer to the certified drawing for the fill section weight.

The end and center eliminator sections should be removed before lifting from the U-bolts or lift points and set back into place once the rig is complete. See **Table 3** for the minimum "H" dimensions for rigging the coil or fill section.

NOTE: Use all of the U-bolts or lift points provided for lifting.

CAUTION: On units shipped as two separate sections, do not assemble sections and attempt to lift the entire unit. The U-bolts and lift points are designed to carry only the weight of their individual section.

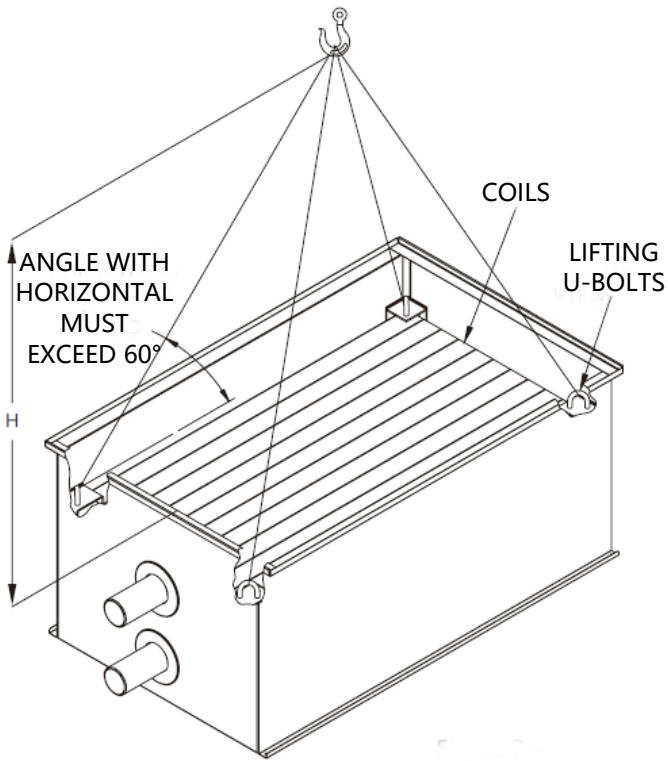

Figure 9 –
Small Coil Section

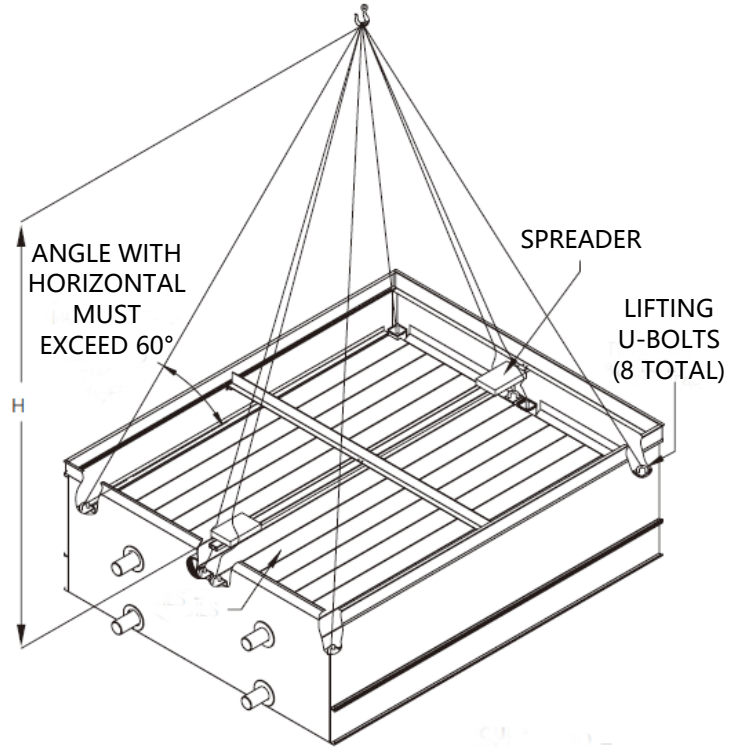

Figure 10 –
Large Coil Section
(2 Coils Wide)

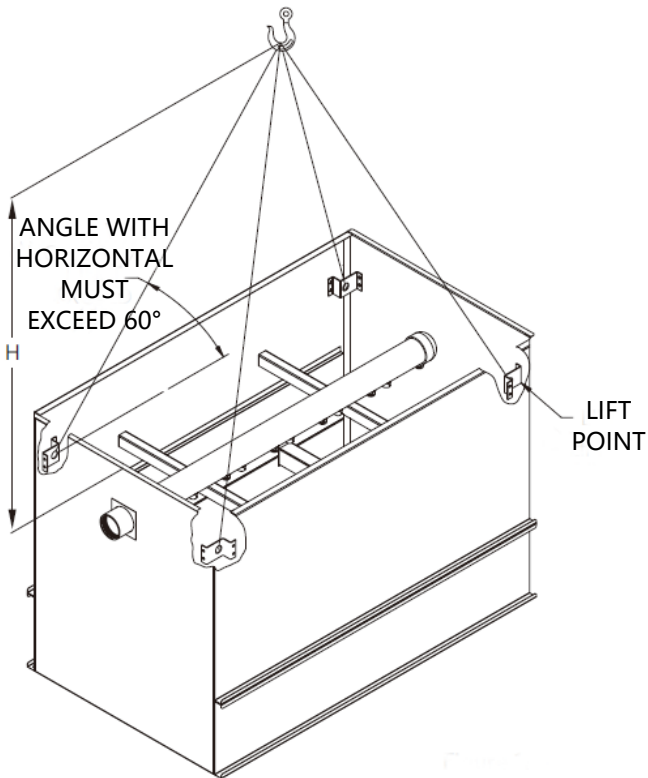

Figure 11 –
Small Fill Section

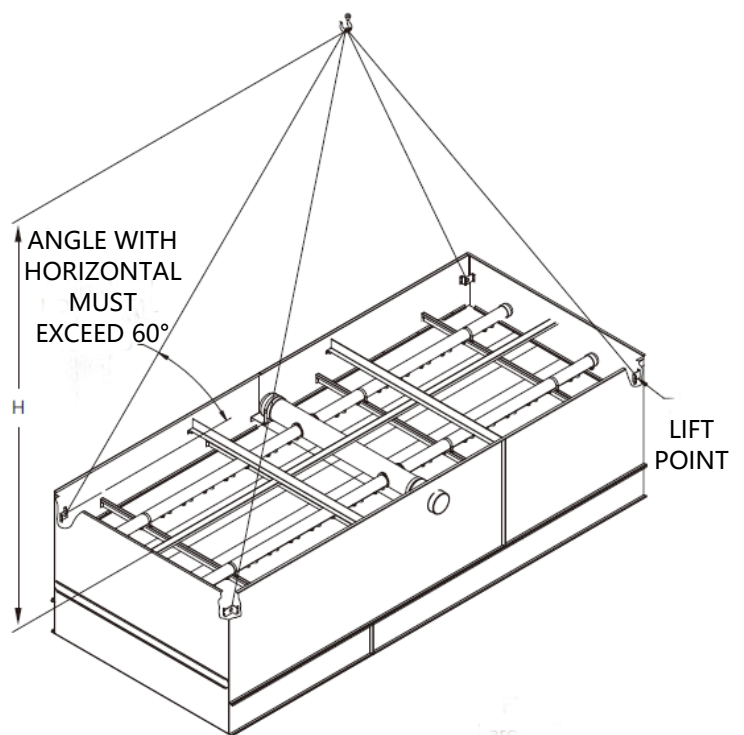

Figure 12 –
Large Fill Section

The recommended method for extended lifts is to use slings under the unit as shown in **Figures 13** and **14** for coil sections and **Figures 15** and **16** for fill sections. Spreader bars should always be used between the cables at the top of the section to prevent damage to the upper flanges.

NOTE: The U-bolts or other lifting points should be used for final positioning only and for lifting where no danger exists. If they are used for extended lifts, safety slings and spreader bars should be provided under the sections as shown.

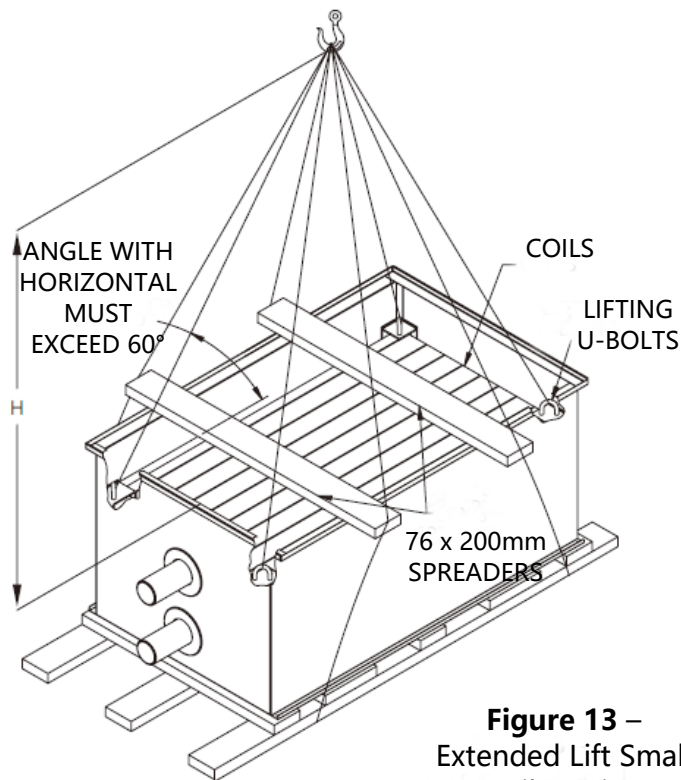

Figure 13 –
Extended Lift Small
Coil Section

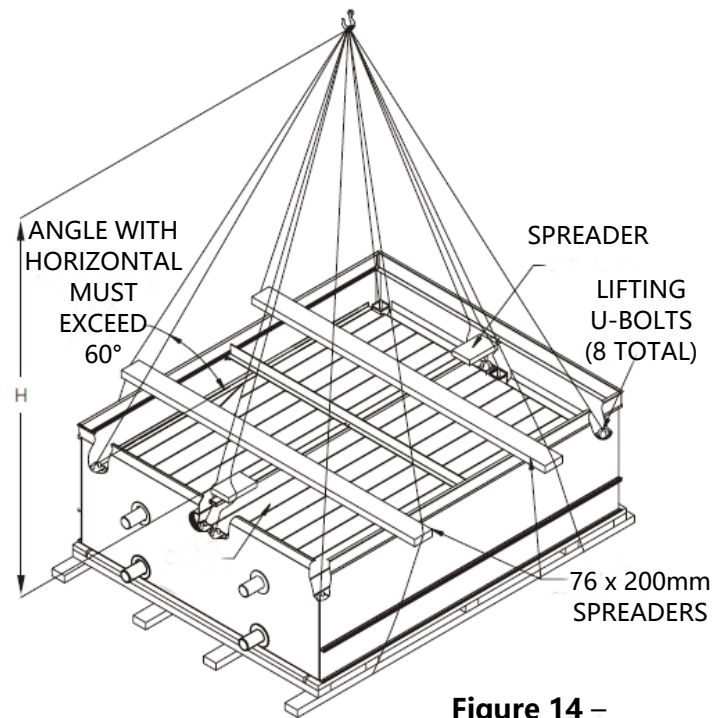

Figure 14 –
Extended Lift Large
Coil Section

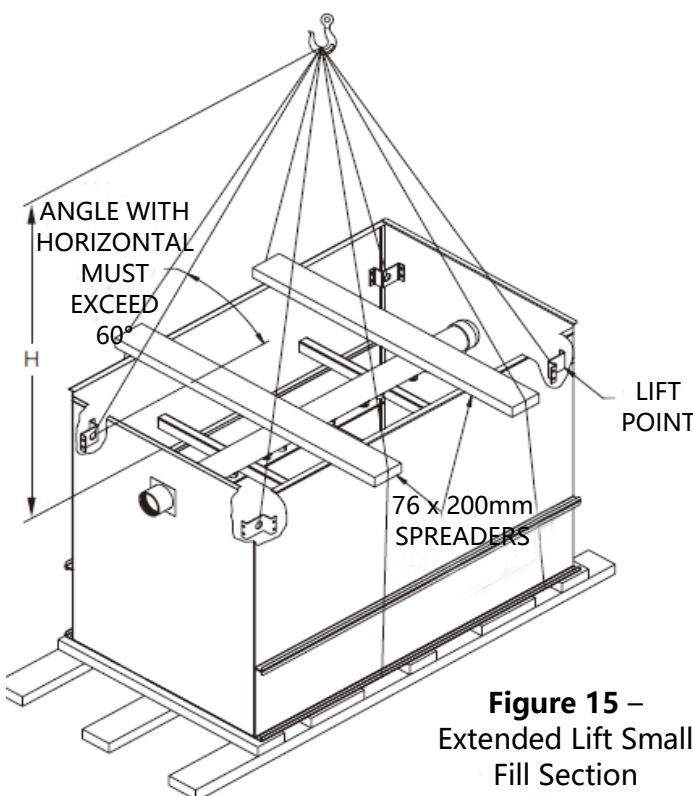

Figure 15 –
Extended Lift Small
Fill Section

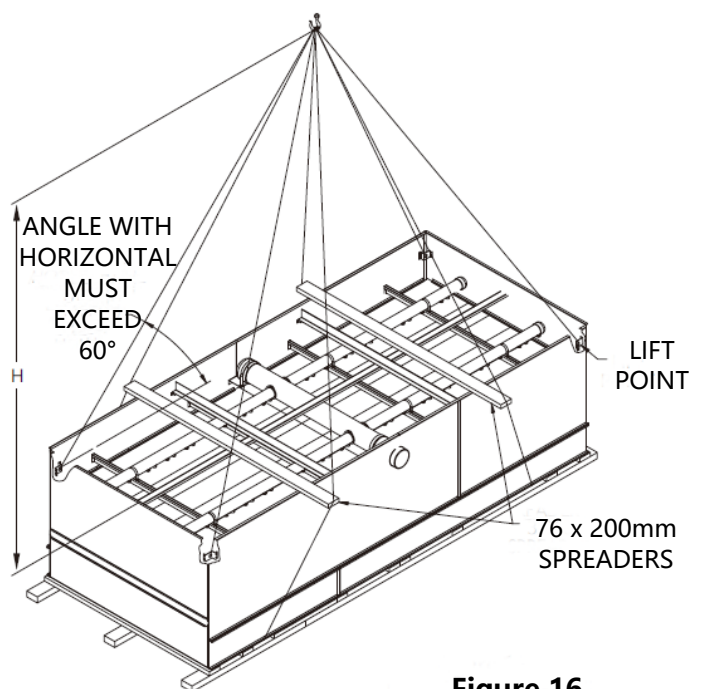

Figure 16 –
Extended Lift Large
Fill Section

See **Table 3** for the minimum “H” dimensions for rigging the coil or fill section for both standard and extended lifts.

Table 3 – Minimum “H” Dimension for Coil and Fill Rigging

Unit (Width x Length) (m)	Minimum “H” (m)
1.2 x 1.8	2.5
1.2 x 2.7	3.1
1.2 x 3.6	4.6
1.2 x 5.4	5.8
1.6 x 3.6	4.6
1.6 x 5.4	5.8
2.4 x 3.6	4.6

Unit (Width x Length) (m)	Minimum “H” (m)
2.4 x 5.4	5.8
2.4 x 7.3	4.6
2.4 x 11	5.8
3 x 3.6	4.6
3 x 5.4	5.8
3 x 7.3	4.6
3 x 11	5.8

Assembly of the Coil/Fill Section to the Pan/Fan Section

Before assembling the coil/fill section to the pan/fan section, remove any loose parts shipped in the pan. On small centrifugal fan units, the fan motor guard is normally shipped in the basin to avoid damage. It should be attached to the unit with the self-tapping screws provided.

Wipe the flanges on the bottom of the coil or fill section. Check to see that the water distribution connection on the coil or fill section is in the correct position relative to the pan-fan section (see certified print). Confirm that sealer tape has been applied to the top of the pan-fan section as shown in **Figures 7 and 8**.

Lower the coil or fill section to within several inches of the pan-fan section, making sure the two sections do not touch and the sealer tape is not disturbed. Place drift pins (see **Figure 17, DETAIL B**) in at least 3 of the corner mounting holes and gradually lower the coil or fill section into place using the drift pins to guide the section down accurately onto the mating flange. On 5.4m and 7.3m long sections, drift pins should be used midway along the sides as well.

Place fasteners in all four corner bolt holes. Then continue to install the rest of the fasteners working from the corners toward the center, using drift pins to align the holes. A fastener must be installed in every hole on the side flanges although none are required on the end flanges. For units with two coil or fill sections, mount the first as described, and then follow the same procedure for the second section.

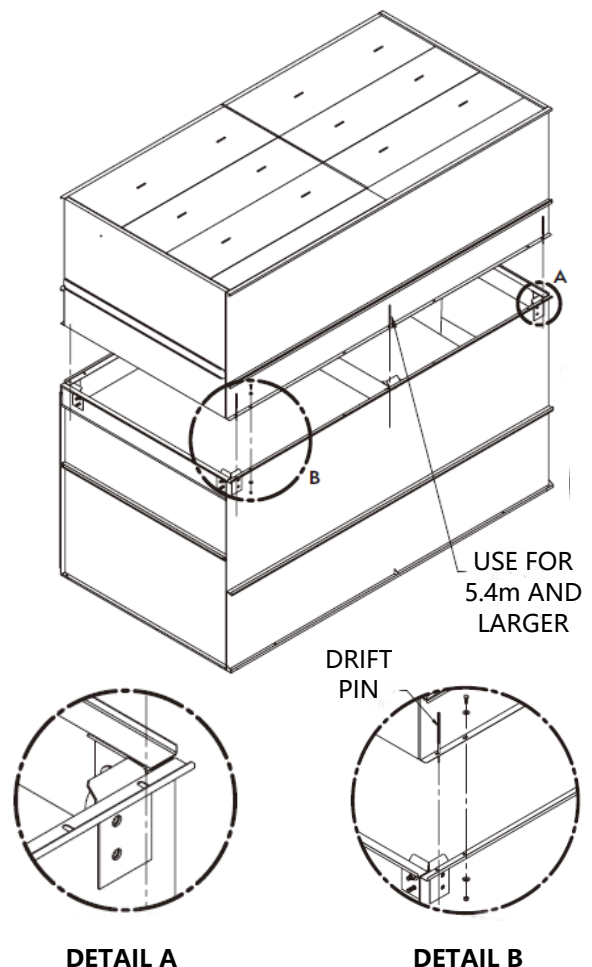

Figure 17 – Mating Coil or Fill Section to Pan-Fan Section

Rigging Complete Units

Units that are shipped with the pan-fan and coil or fill sections assembled can be lifted into final position on the structural steel as a complete unit. U-bolts or lift points are provided in the coil or fill section below the eliminators for lifting and final positioning (**Figure 18** and **Figure 20**).

NOTE: Use all of the U-bolts or lift points provided for lifting.

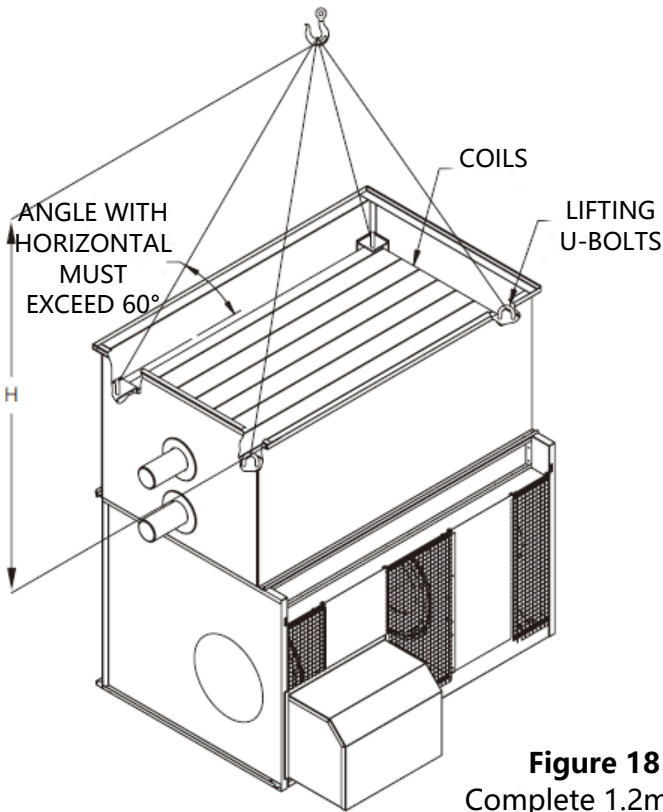

Figure 18 –
Complete 1.2m Wide
Condenser and
Cooler Unit

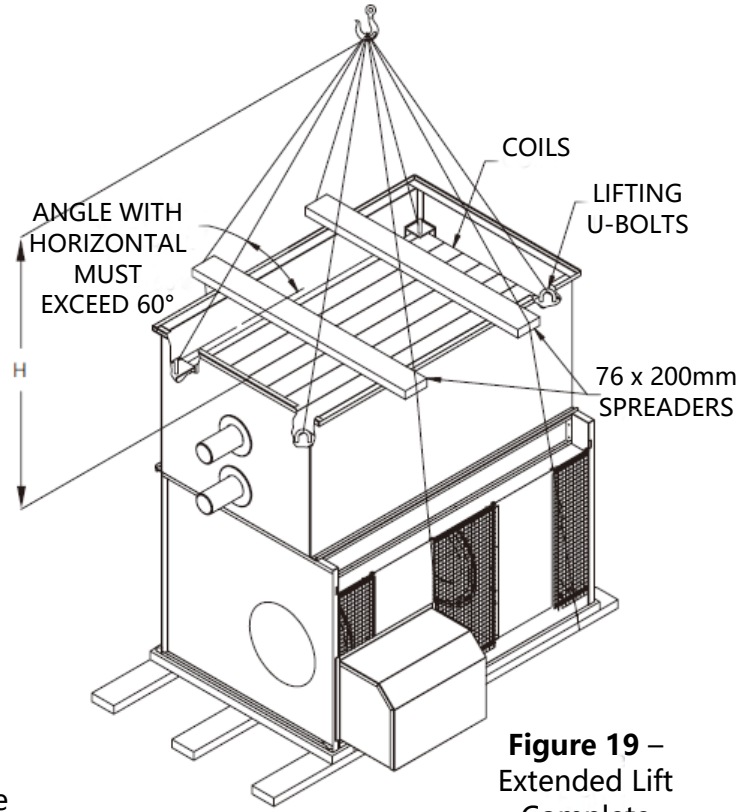

Figure 19 –
Extended Lift
Complete
Condenser and
Cooler Unit

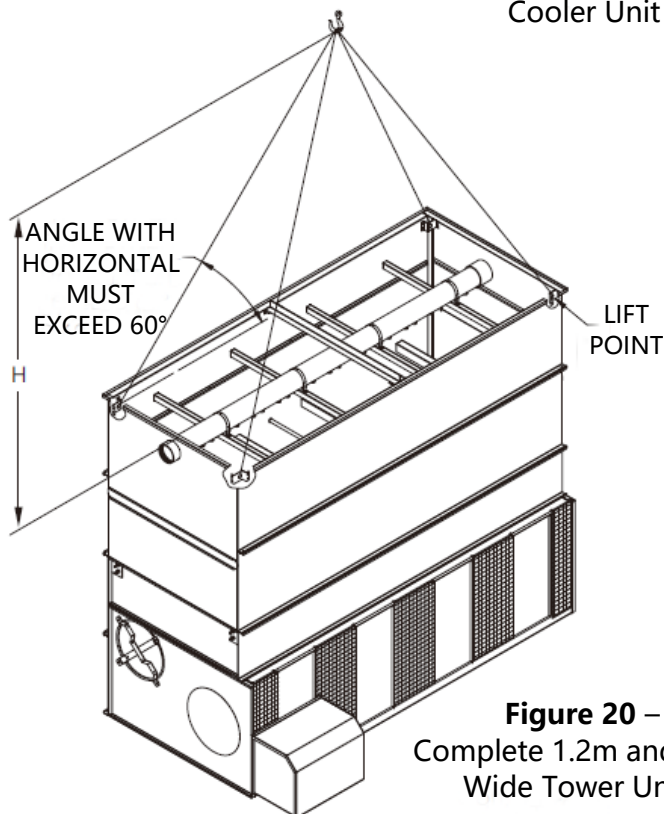

Figure 20 –
Complete 1.2m and 1.6m
Wide Tower Units

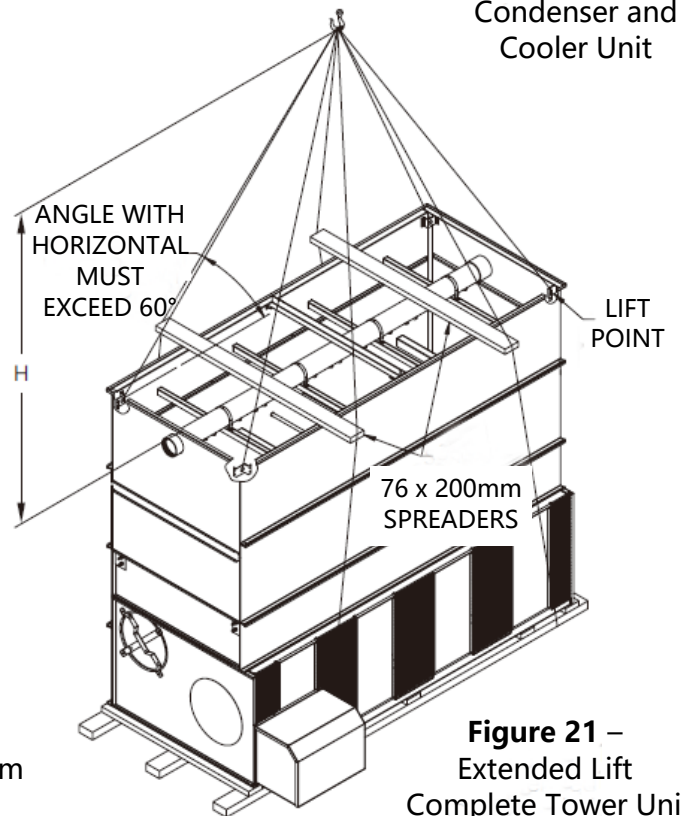

Figure 21 –
Extended Lift
Complete Tower Unit



The recommended method for extended lifts is to use slings under the unit as shown in **Figure 19** and **Figure 21**. Spreader bars should always be used between the cables at the top of the section to prevent damage to the upper flanges.

NOTE: The U-bolts or other lifting points should be used for final positioning only and for lifting where no danger exists. If they are used for extended lifts, safety slings and spreader bars should be provided under the sections as shown.

See **Table 4** and **Table 5** for the minimum "H" dimensions for rigging the entire unit for both standard and extended lifts.

Table 4 – Minimum "H" Dimension for Complete Condenser and Cooler Unit Rigging

Unit (Width x Length) (m)	Minimum "H" (m)
1.2 x 1.8	2.5
1.2 x 2.7	3.1

Table 5 – Minimum "H" Dimension for Complete Tower Unit Rigging

Unit (Width x Length) (m)	Minimum "H" (m)
1.2 x 1.8	2.5
1.2 x 2.7	3.1
1.2 x 3.6	4.6
1.2 x 5.4	5.8
1.6 x 3.6	4.6
1.6 x 5.4	5.8
2.4 x 3.6	4.6
2.4 x 5.4	5.8
2.4 x 7.3	4.6
2.4 x 11	5.8
3 x 3.6	4.6
3 x 5.4	5.8
3 x 7.3	4.6
3 x 11	5.8

Optional Tapered or Straight-Sided Hood Section

Some units may be supplied with an optional discharge hood section. This section will ship from the factory as a separate item or loosely mounted on top of either the pan-fan section, coil or fill section to reduce freight charges. Each hood section is equipped with U-bolts located at the four corners for lifting and final positioning (**Figure 22**). Always use safety slings for extended lifts or where any hazard exists.

NOTE: When combined with other sections, the hood must be removed prior to any lift. In all cases the hood section must be rigged as a separate part.

Once the coil or fill section has been secured to the pan-fan section, wipe the top flanges to remove any dirt or moisture. Place sealer tape over the mounting hole centerline on the side flanges. Apply two strips of sealer tape, one partially overlapping the other, on the end flanges as shown in **Figures 7 and 8**. Remove any shipping blocks or other obstructions. Lower the hood onto the top flange of the coil or fill section.

Install the fasteners in all four corners as shown in **Figure 22**. For 5.4m long hoods, two additional fasteners are provided and are to be fastened in the middle of each side.

NOTE: Always lift the hood separately and follow the rigging sequence shown.

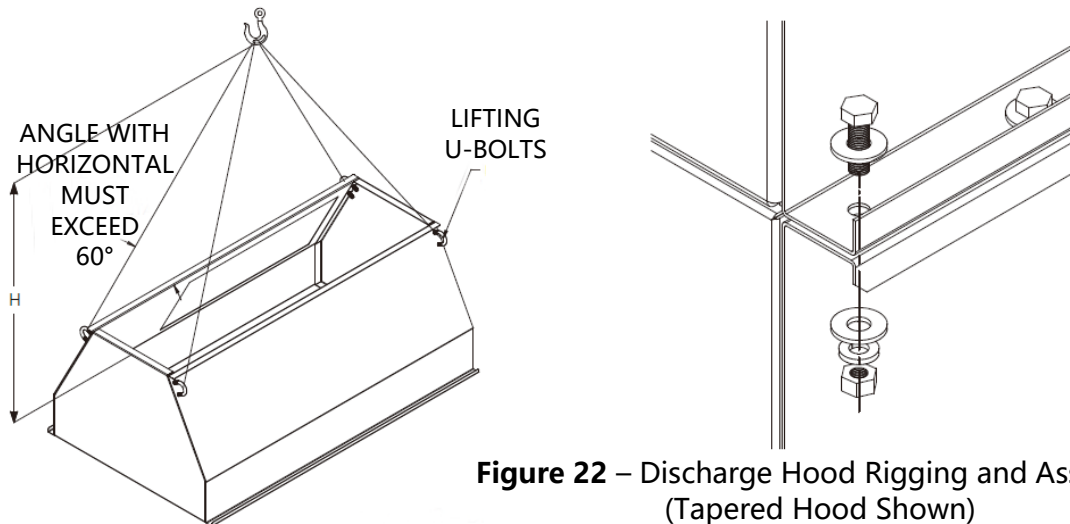

Figure 22 – Discharge Hood Rigging and Assembly (Tapered Hood Shown)

See **Table 6** for the minimum “H” dimensions for rigging the discharge hood for both standard and extended lifts.

Table 6 – Minimum “H” Dimension for Rigging Discharge Hoods and Discharge Attenuation

Unit (Width x Length) (m)	Minimum “H” (m)
1.2 x 1.8	2.5
1.2 x 2.7	3.1
1.2 x 3.6	4.6
1.2 x 5.4	5.8
1.6 x 3.6	4.6
1.6 x 5.4	5.8
2.4 x 3.6	4.6

Unit (Width x Length) (m)	Minimum “H” (m)
2.4 x 5.4	5.8
2.4 x 7.3	4.6
2.4 x 11	5.8
3 x 3.6	4.6
3 x 5.4	5.8
3 x 7.3	4.6
3 x 11	5.8

Optional Discharge Attenuation Section

Some units may be supplied with an optional discharge attenuation section. This section will ship from the factory as a separate item or mounted on top of either the pan-fan section, coil or fill section to reduce freight charges. Each discharge attenuation section is equipped with U-bolts located at the four corners for lifting and final positioning (**Figure 23**). Always use safety slings for extended lifts or where any hazard exists.

NOTE: When combined with other sections, the attenuation must be removed prior to any lift. In all cases the hood section must be rigged as a separate part.

Once the coil or fill section has been secured to the pan-fan section, wipe the top flanges to remove any dirt or moisture. Place sealer tape over the mounting hole centerline on the side flanges. Apply two strips of sealer tape, one partially overlapping the other, on the end flanges as shown in **Figures 7 and 8**.

Lower the attenuation section to within several inches of the coil or fill section making sure the two sections do not touch and the sealer tape is not disturbed. Place drift pins (see **Figure 24**) in at least 3 of the corner mounting holes and gradually lower the discharge attenuation section into place using the drift pins to guide the section down accurately onto the mating flange. On 5.4m and 7.3m long sections, drift pins should be used midway along the sides as well.

Place fasteners in all four corner bolt holes. Then continue to install the rest of the fasteners working from the corners toward the center, using drift pins to align the holes. A fastener must be installed in every hole on the side flanges although none are required on the end flanges. For units with two attenuation sections, mount the first as described, and then follow the same procedure for the second section.

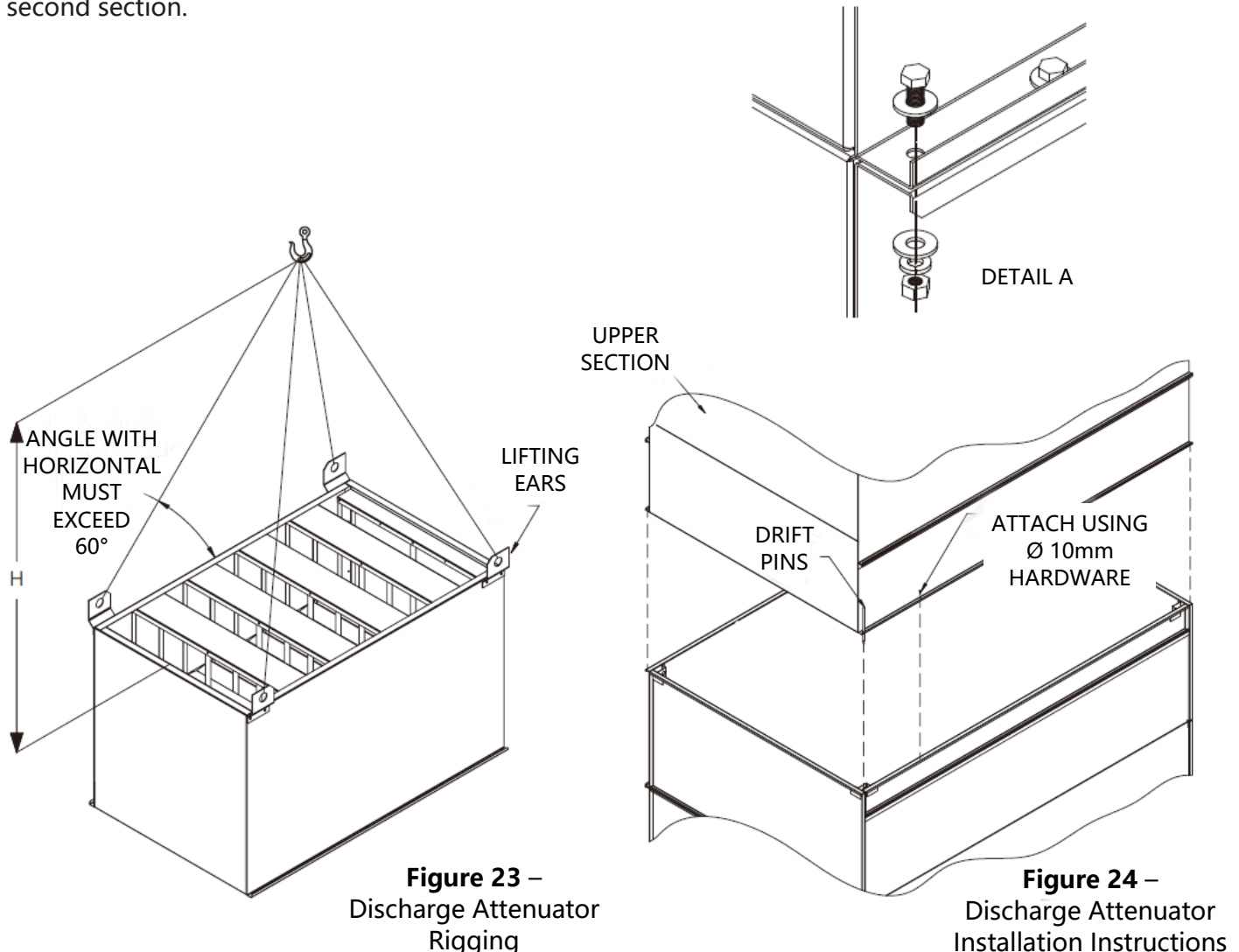

Figure 23 –
Discharge Attenuator
Rigging

Figure 24 –
Discharge Attenuator
Installation Instructions

Optional Intake Attenuation Section

Some units may be supplied with an optional intake attenuation section. This section will ship from the factory as a separate item or mounted on top of either the pan-fan section or coil or fill section to reduce freight charges. Each intake attenuation section is equipped with U-bolts located at the four corners for lifting and final positioning (**Figure 25**). Always use safety slings for extended lifts or where any hazard exists.

NOTE: When combined with other sections, the attenuation must be removed prior to any lift. In all cases, the attenuation section must be rigged as a separate part.

Move the attenuation section to within several inches of the fan intake section. Place drift pins in at least 3 of the corner mounting holes and gradually move the intake attenuation section into place using the drift pins to guide the section accurately onto the mating flange. On 5.4m and 7.3m long sections, drift pins should be used midway along the sides as well. See **Table 7** for the minimum "H" dimensions for rigging the intake attenuation section for both standard and extended lifts.

Table 7 – Minimum "H" Dimension for Rigging Intake Attenuation Section

Unit (Width x Length) (m)	Minimum "H" (m)
1.2 x 1.8	2.5
1.2 x 2.7	3.1
1.2 x 3.6	4.6
1.2 x 5.4	5.8
1.6 x 3.6	4.6
1.6 x 5.4	5.8
2.4 x 3.6	4.6

Unit (Width x Length) (m)	Minimum "H" (m)
2.4 x 5.4	5.8
2.4 x 7.3	4.6
2.4 x 11	5.8
3 x 3.6	4.6
3 x 5.4	5.8
3 x 7.3	4.6
3 x 11	5.8

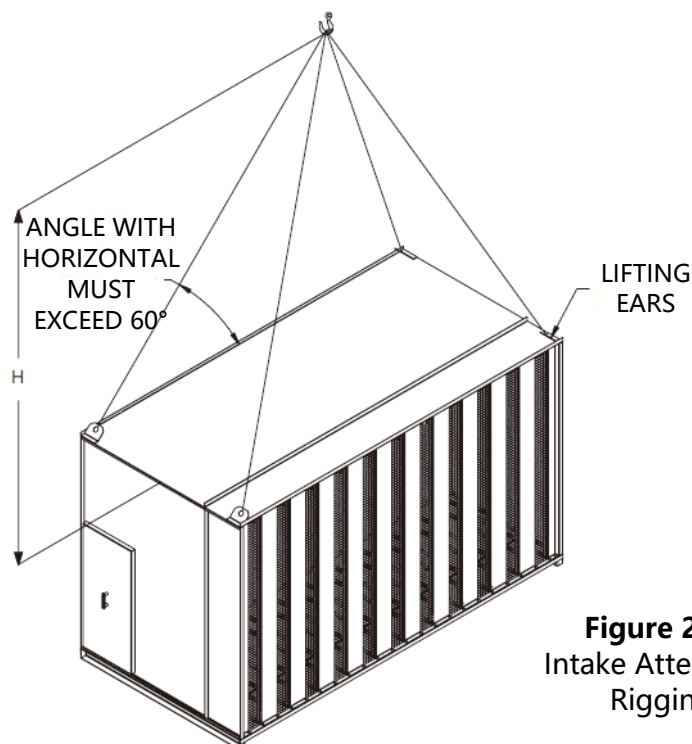

Figure 25 – Intake Attenuator Rigging

Motor Installation (1.2m and 1.6m wide models)

1. Study **Figure 26** before installing the motor bases on the unit.
2. Insert the lifting device into the lifting hole **A** provided in the motor base.
3. Lift the motor/motor base assembly and align holes **B** to **B1** and **C** to **C1**. Insert the 13mm diameter pivot bolts with flat washer **D**. Install flat washer, nut and jam nut **E** on the pivot bolt. **DO NOT OVERTIGHTEN.**
4. Insert the J-bolts **F** into holes **G**. Install flat washers and cotter pins **H**. Place nuts, lock washers, and flat washers **J** on the threaded portion of J-bolts. Their final location will be behind the motor base installed next.
5. Insert the J-bolts into the holes **K** in the motor base. Install flat washers, lock washers, and nuts **L**. Remove the lifting device from the motor base and position motor base toward the unit for belt installation.
6. Install the belts **M** around the fan sheave and motor sheave (**Figure 27**). Tighten belts by adjusting nuts on J-bolts. Do not over tension the belts. When the belts are properly adjusted, the deflection at the center of the belt should be approximately 13mm with moderate hand pressure.
7. Measure the distance from the motor base to the J-bolt mounting angles to ensure that both sides of the base are located the same distance from the unit. This should ensure that the sheaves are properly aligned since they were pre-set at the factory.
8. As a final check, lay a straight edge from sheave to sheave (**Figure 28**). There should be 4 point contact. Adjust the position of the motor sheave if necessary.
9. To install the motor guard **N**, line up the holes and fasten with the self-tapping screws **P** (**Figure 27**). Check to ensure that the motor guard does not make contact with the drive sheave or belts.

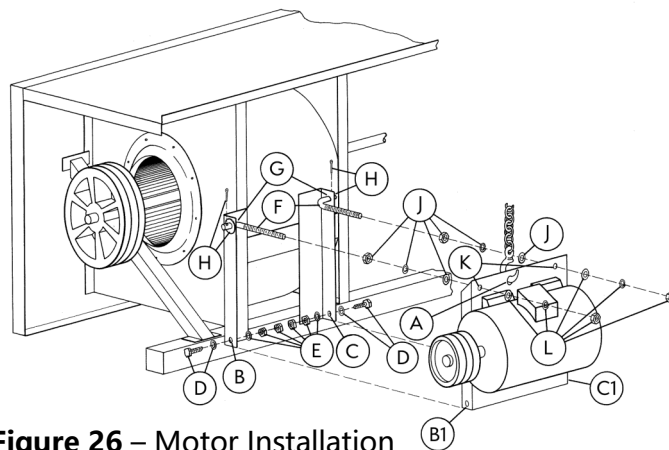

Figure 26 – Motor Installation

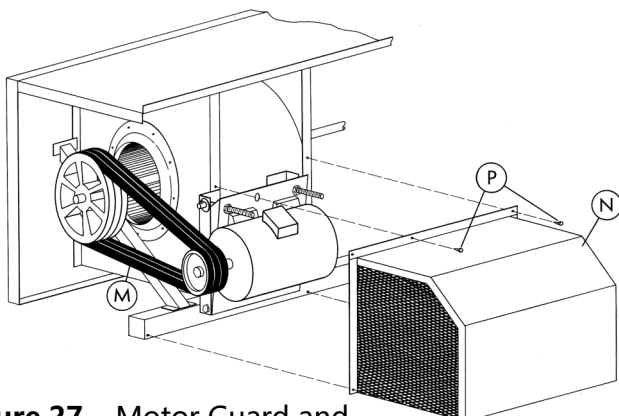

Figure 27 – Motor Guard and Powerband Belt Installation

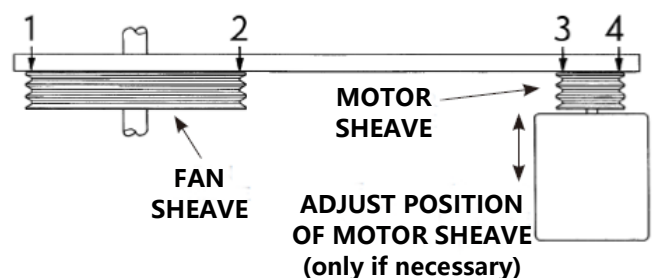

Figure 28 – Sheave Alignment Check



Final Assembly and Start-Up Details

Shipping Materials – Remove any wood chocks, spare parts, or miscellaneous items that have been placed inside the unit for shipping purposes. Clean all debris from the basin.

Pump Discharge Line – Connect the riser pipe from the pump discharge on the pan-fan section to the riser pipe on the coil section using the flexible connection and hose clamps provided.

Bleed-off Line – A bleed-off line and valve are installed on the unit when shipped with a pump. On units shipped without a pump (remote sump applications) make sure a bleed-off line and valve are properly sized and installed on the discharge side of the pump and connected to a convenient drain. In either case, the bleed-off valve should be fully open.

Strainer – Check the strainer in the basin to ensure that it is in its proper location over the pump suction.

Screens – Protective air inlet screens are provided across the front of the fan section of all models. Screens are not provided on the bottom of the fan section since most of the units are mounted on steel beams, either on the roof or at ground level. If units are installed in an elevated position, bottom screens are recommended for safety protection and should be provided by the installing contractor.

Float Valve Adjustment – The float valve is pre-set at the factory; however, adjustment(s) should be checked after rigging. The float valve should be adjusted so that the center of the float is 1" below the center of the overflow connections when the valve is in the fully closed position. Raise or lower the float by using the wing nuts on the vertical threaded rod. Do not adjust the horizontal rod. During normal operation, the water level will drop 3" to 4" below the overflow in condensers and coolers. See **Table 8** for normal operating level for the LS Series units.

NOTE: The float valve has an available operating pressure between 140 and 340 kPa.

Fan Rotation – Bump start and check the fans for proper rotation. Directional arrows are placed on the outside of centrifugal fan housings. Note, unless the unit has been sized for dry operation, the fan motor will overamp unless the pump is also running.

Pump Rotation – Once the basin is filled with water, bump start and check the pump for proper rotation. Directional arrows are found on the pump impeller housing.

Fan Shaft Sleeve Bearings – Lubricate the intermediate sleeve bearing(s) with the oil provided in the rigging pack before start-up. The reservoir should be checked several times during the first week to ensure that the oil reserve is brought up to full capacity. After the first week of operation, lubricate the bearing(s) every 1000 hours or every 3 months. High temperatures or poor environmental conditions may necessitate more frequent lubrication. The oil reservoir consists of a large felt-packed cavity within the bearing. It is not necessary to maintain the oil level within the filler cup.

NOTE: This is for 1.2m wide LS series units only.

Table 8 – Minimum Operating Level

Unit	Minimum Operating Level (mm)
1.2 x 1.8	280
1.2 x 2.7	280
1.2 x 3.6	280
1.2 x 5.4	280
1.6 x 3.6	280
1.6 x 5.4	280
2.4 x 3.6	305

Unit	Minimum Operating Level (mm)
2.4 x 5.4	380
2.4 x 7.3	305
2.4 x 11	380
3 x 3.6	305
3 x 5.4	380
3 x 7.3	305
3 x 11	380

Freeze Protection

The simplest and most effective way of keeping the recirculated water from freezing is to use a remote sump. With a remote sump, when the recirculating water pump is shut off all recirculating water drains back to the sump.

If a remote sump is not being used, pan heaters are available. However, the basin heater will not prevent the external water lines, pump or pump piping from freezing. For installations where water will be left in the basin during freezing conditions, the make-up water supply, overflow and drain lines, as well as the pump and pump piping up to the overflow level must be heat traced and insulated to protect them from damage. Any other connections or accessories at or below the water level must also be heat traced and insulated.

A condenser or cooler cannot be operated dry (fans on, pump off) unless the water is completely drained from the pan. The pan heaters are sized to prevent pan water from freezing only when the fans are turned off.

Water Treatment

Proper water treatment is an essential part of the maintenance required for evaporative cooling equipment. Galvanized equipment should be passivated prior to equipment startup to avoid the formation of white rust. For more information on passivation and white rust, please download a copy of EVAPCO's Engineering Bulletin 36 at www.evapco.com. The spray water and the fluid inside the heat transfer coil or fill should both be maintained with a water treatment program to ensure efficient system operation while maximizing the equipment's service life. For more information on recommended water chemistry for EVAPCO equipment, see the Operation and Maintenance Instructions for this equipment.

Maintenance

Once the installation is complete and the unit is turned on, it is important that it be properly maintained. Maintenance is not difficult or time-consuming, but must be done regularly to assure full performance of the unit. Refer to the Operation and Maintenance Instructions supplied with the unit for proper maintenance procedures.



Accessory Location Checklist

Accessories can ship in a variety of locations depending on the type of accessory, the size of the unit, and the accessories purchased with the unit. See **Table 9** for a guide to accessory location.

Table 9 – Unit Accessory Shipping Location

Unit Accessories	Shipping Location
Aluminum Ladder	Shipping Location is Unit and Accessory Dependent - If Space is Available: Strapped Inside Unit Basin - If No Space is Available: Shipped Separately on Truck Bed
Discharge Attenuation	Shipping Location is Unit Dependent - 1.2m Wide Units: Shipped Separately on Truck Bed - 2.4m Wide Units and Larger: Mounted Loosely Bolted on Basin or Coil Casing
Discharge Hood with Dampers	Shipping Location is Unit Dependent - 1.2m Wide Units: Shipped Separately on Truck Bed - 2.4m Wide Units and Larger: Mounted Loosely Bolted on Basin
Electric Basin Heater	Shipping Location is Unit Dependent - End Mounted Heater: Installed in Unit Basin - Side Mounted Heater: Strapped Inside Unit Basin
Electric Basin Heater Control Panel	Shipping Location is Dependent on Control Panel Size - If Space is Available: Mounted on Unit Basin - If No Space is Available: Boxed, Wrapped and Wire Tied Inside Unit Basin
Electric Basin Heater Low Water Cutout	Shipped in Rigging Box Strapped Inside Unit Basin
Electric Basin Heater Thermostat	Shipping Location is Unit Dependent - End Mounted Thermostat: Mounted on Unit Basin - Side Mounted Thermostat: Shipped in Rigging Box
Electronic Water Level Control Probes	Mounted in PVC standpipe
Electronic Water Level Control	PVC Standpipe Strapped Inside Unit Basin
Factory Mounted Crossover Piping	Welded to Coil Connections
Fan Screens (If not mounted)	Shipping Location is Unit and Accessory Dependent - If Space is Available: Strapped Inside Unit Basin - If No Space is Available: Crated and Shipped Separately on Truck Bed
Hot Water or Steam Coil	Installed in Unit Basin
Inlet Attenuation	Shipped as a Separate Section
Motor (If not mounted)	Installed In Unit Basin
Remote Sump Trash Screen	Installed In Unit Basin
Rigging Hardware	Shipped in Rigging Box Strapped Inside Unit Basin
Safety Cage	Attached to the Ladder
Sealer Tape	Shipped in Rigging Box Strapped Inside Unit Basin
Sump Sweeper Piping with and without High Flow Eductors	Installed in Unit Basin
Vibration Switch	Mounted in Fan Section



NOTES:



EVAPCO ASIA PACIFIC • 1159 Luoning Rd, Baoshan Industrial Zone, Shanghai, China 200949

PHONE: (86) 21-6687-7786 • FAX: (86) 21-6687-7008 • E-MAIL: marketing@evapcochina.com